

Application of Linear Switched Reluctance Motors to Precision Position Control

*Wai-Chuen Gan, *G. P. Widdowson, *Michael S. W. Tam and **Norbert C. Cheung

*Motion Group, ASM Assembly Automation Hong Kong Ltd., Kwai Chung, NT,
Hong Kong SAR, China. Email: wcgan@asmpt.com

**Department of Electrical Engineering, The Hong Kong Polytechnic University, Hung Hom, Kowloon,
Hong Kong SAR, China. Email: eencheun@polyu.edu.hk

Abstract—This paper presents the application of linear switched reluctance motors (LSRMs) to precision position control. In general, a typical AC industrial servo system consists of a motion controller for torque, velocity and position loop control, a current tracking amplifier with a standard three-phase output bridge and two current feedback sensors only, the motor to be controlled and a position feedback encoder. An LSRM is developed for the above typical AC servo system without any modifications on the hardware setup. The magnet-free and possible high-temperature operation features allow LSRMs to replace linear permanent magnet (PM) motors in some special applications such as conveyor systems in an oven. On the other hand, the micrometer precision position control of LSRMs addressed in this paper is also new to literature.

I. INTRODUCTION

Linear switched reluctance motors (LSRMs) have never been a popular choice for direct-drive linear motion control systems; because they are difficult to control and their outputs have high force ripples. It is also due to the fact that the characteristic of the LSRM is highly dependent on its complex magnetic circuit, which is difficult to model, simulate, and control. There is not much in recent literature concerning high performance motion control of switched reluctance linear drive systems. It was only during recent years where we see a general surge of interest in the switched reluctance motor [1], [10]. This was mostly due to the advancement of power electronics and digital signal processing, and the continuous trend of simplifying the mechanics through advance control strategy.

In comparison to the linear AC permanent magnet (PM) motor or the linear AC induction motor, LSRMs possess many advantages that other actuators did not have. Firstly, manufacturing of the LSRM is simple, and it is very suitable for high-precision travel over long distances. Secondly, unlike other types of motion actuators, mechanical couplings, lead/ball screws, magnets, and brushes are not required in LSRMs. Special mechanical adjustments or alignments are also not necessary either. Finally, in comparison to PM linear motors, the proposed actuator has a much simpler structure and is less expensive. It is also more robust, more fault tolerant, and has less overheating problems. Therefore, LSRMs are potential candidates for high performance linear motion drives.

Fig. 1 shows a general-purpose three-phase motor controller. The main component of the motion control system is a motion controller which performs the profile generation, as well as the torque, velocity and position loop control. The standard current-tracking amplifier consists of a three-phase output bridge (six IGBTs) and two current feedback sensors. Two

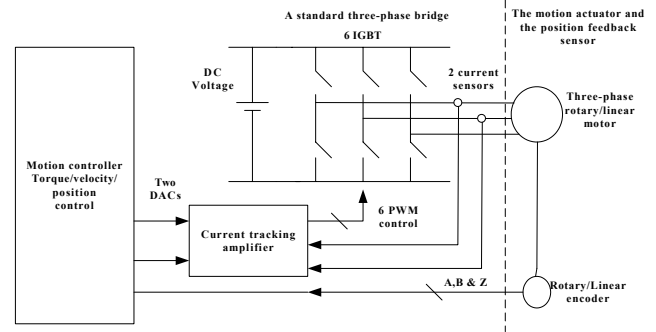

Fig. 1. Block diagram of a general-purpose three-phase motor controller.

Digital-to-Analog Converter (DAC) commands are received from the motion controller. On the other hand, the position encoder installed on the actuator feeds the incremental A, B and the index Z signals to the motion controller for the commutation and position control purposes. With the structure shown in Fig. 1, both three-phase linear/rotary PM/induction motors can be driven by only changing a proper control algorithm in the host controller but without any hardware reconfiguration. However, a hardware change is needed in order to drive a three-phase rotary/linear SRM. For example, the driving stage may be reconfigured as three asymmetric bridges [1] using three current sensors, requiring three DAC commands from the motion controller. This loss in generality for a three-phase LSRM drive is an obstacle to promote its popularity in industrial applications.

In general, the applications of LSRMs are mainly focused on speed output control [1] such as transportation systems [10]. Researchers did not pay much attention to precision position control of LSRMs until [2], [3], [4]. To achieve high-precision position control using LSRMs, the key point is to apply a sophisticated force linearization scheme so that the control of a highly nonlinear LSRM can be as easy as that of a DC motor. In addition, the inner current loop and the outer velocity and position loops are also required to be properly designed so as to provide an accurate position tracking response.

An LSRM control system for high-precision position accuracy was developed by the authors and the results can be found in [2], [3], [4]. In this paper, a sophisticated force linearization algorithm is first proposed for the LSRM. Then with a proper reconfiguration of the three-phase motor windings and the insertion of three diodes, the LSRM can be driven by a standard

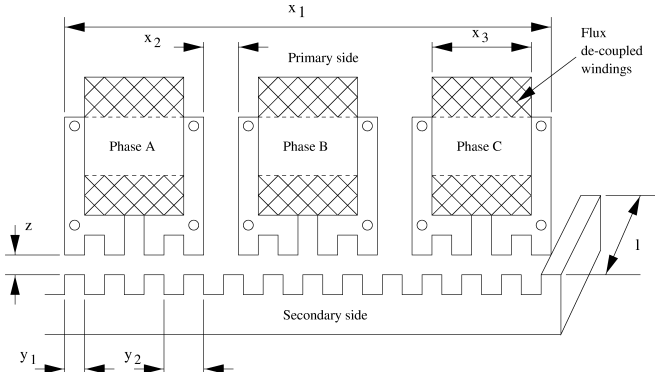

Fig. 2. LSRM design schematic.

three-phase bridge inverter with two current feedback sensors only. Therefore, an LSRM system, with direct compatibility to existing AC servo motors, can be developed with the proposed force linearization and novel driving schemes. The only change for the proposed system is the easily reconfigurable control software inside the motion controller.

The paper is organized as follows. Section II gives a brief review on the construction and development of the LSRM. In Section III, the proposed force linearization algorithm for the LSRM is addressed. In Section IV, the three-phase motor winding reconfiguration and the novel winding excitation scheme are described, so that the proposed LSRM can be driven by a standard three-phase bridge inverter. The system integration and experimental results are shown in Section V to validate the proposed LSRM system. Some concluding remarks are given in Section VI.

II. REVIEW ON THE CONSTRUCTION AND MODELING OF THE LSRM

The novel actuator design is based on switched reluctance technology [3]. The magnet-free structure makes this actuator particularly suitable for harsh environments such as high temperature and high pressure. The flux de-coupled rotor arrangement leads a more simple motor model because there are no mutual inductances between windings. Fig. 2 shows the design schematic of the LSRM system.

The motor is integrated on a precision linear motion guide. The tracking guide and the core of the windings are laminated with 0.5mm silicon-steel plates. Table I shows the design parameters of the proposed LSRM. The switched reluctance linear drive system has a highly nonlinear characteristic due to its nonlinear flux behavior. The following is the nonlinear mathematical model of the LSRM:

$$v_j = R_j i_j + \frac{\partial \lambda_j(x, i_j)}{\partial x} \frac{dx}{dt} + \frac{\partial \lambda_j(x, i_j)}{\partial i_j} \frac{di_j}{dt} \quad (1)$$

$$f_e = \sum_{j=1}^3 \frac{\partial \int_0^{i_j} \lambda_j(x, i_j) di_j}{\partial x} \quad (2)$$

$$f_e = M \frac{d^2 x}{dt^2} + B \frac{dx}{dt} + f_l \quad (3)$$

where v_j , i_j , R_j and λ_j are the phase voltage, phase current, phase resistance and phase flux linkage respectively, x is the

TABLE I
DESIGN PARAMETERS OF THE LSRM.

Power output	100 W
Traveling distance	300 mm
Maximum load	5kg
Pole width	5 mm (y_1)
Pole pitch	10 mm (y_2)
Coil separation	8.333 mm (x_2)
Winding width	15 mm (x_3)
Track width	25 mm (l)
Air gap width	0.4 mm (z)
Aligned phase inductance	19.8mH
Unaligned phase inductance	11.4 mH

travel distance, f_e is the generated electromechanical force, f_l is the external load force, M and B are the mass and the friction constant respectively.

III. FORCE LINEARIZATION SCHEME FOR LSRM

The most difficult part in controlling an LSRM is how to compensate the nonlinear force generation function so that the input command current is directly proportional to the output force. There are many different methods to preform the force linearization algorithm [1], [10] and the most common way is to employ the force-position-current look-up table scheme. However, the databases of the look-up tables need to be remeasured for different LSRMs, a procedure that may not be acceptable to mass production of LSRM systems with different dimensions and force constant requirements. Recently, exact force linearization for LSRMs was developed such that a closed form solution can be given for different LSRMs [11]. The required parameters are only the change of the inductance values from unaligned to aligned position and some mechanical dimensions, which are easy to obtained in comparison to the creation of a three-dimensional look-up table. The exact force linearization scheme will be implemented in this proposed LSRM system.

Basically, the exact force linearization scheme can be further divided into two stages as shown in Fig. 3. The first stage is to determine which phase or two phases can be excited at different locations and force input within a pole pitch. The two phase excitation algorithm can definitely smooth the

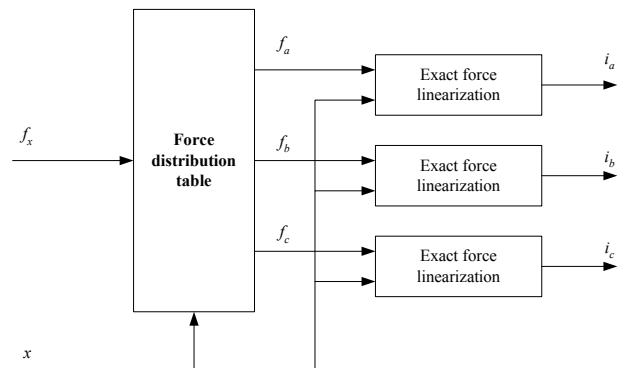

Fig. 3. Two-stage force linearization scheme.

TABLE II
CURRENT EXCITATION TABLE FOR A SINGLE POLE PITCH.

Region	Range(mm)	For +ve force	For-ve force
1	0-1.667	I_b	I_c, I_a
2	1.667-3.333	I_b, I_c	I_a
3	3.333-5	I_c	I_a, I_b
4	5-6.667	I_c, I_a	I_b
5	6.667-8.333	I_a	I_b, I_c
6	8.333-10	I_a, I_b	I_c

force ripples during the transition period from one region to another [10]. Table II shows the current excitation table for the proposed LSRM.

After the phase excitation sequence is found, the next stage is to perform the force linearization algorithm. The basic idea of the proposed algorithm is to evaluate the required current according to the input position and the force command. The exact force-position-current inverse functions for single-phase and two-phase excitation are given as follows [11].

For single-phase excitation:

$$I_a = \sqrt{\frac{-k_t f_a}{\sin\left(\frac{2\pi x}{y_2}\right)}},$$

$$I_b = \sqrt{\frac{-k_t f_b}{\sin\left(\frac{2\pi x}{y_2} - \frac{2\pi}{3}\right)}},$$

$$I_c = \sqrt{\frac{-k_t f_c}{\sin\left(\frac{2\pi x}{y_2} + \frac{2\pi}{3}\right)}}$$

For two-phase excitation:

$$I_a = \sqrt{\frac{-k_t f_a \sin\left(\frac{2\pi x}{y_2}\right)}{\sin^2\left(\frac{2\pi x}{y_2}\right) + \sin^2\left(\frac{2\pi x}{y_2} + \frac{2\pi}{3}\right)}},$$

or

$$I_a = \sqrt{\frac{-k_t f_a \sin\left(\frac{2\pi x}{y_2}\right)}{\sin^2\left(\frac{2\pi x}{y_2}\right) + \sin^2\left(\frac{2\pi x}{y_2} - \frac{2\pi}{3}\right)}},$$

$$I_b = \sqrt{\frac{-k_t f_b \sin\left(\frac{2\pi x}{y_2} - \frac{2\pi}{3}\right)}{\sin^2\left(\frac{2\pi x}{y_2} - \frac{2\pi}{3}\right) + \sin^2\left(\frac{2\pi x}{y_2}\right)}},$$

or

$$I_b = \sqrt{\frac{-k_t f_b \sin\left(\frac{2\pi x}{y_2} - \frac{2\pi}{3}\right)}{\sin^2\left(\frac{2\pi x}{y_2} - \frac{2\pi}{3}\right) + \sin^2\left(\frac{2\pi x}{y_2} + \frac{2\pi}{3}\right)}},$$

$$I_c = \sqrt{\frac{-k_t f_c \sin\left(\frac{2\pi x}{y_2} + \frac{2\pi}{3}\right)}{\sin^2\left(\frac{2\pi x}{y_2} + \frac{2\pi}{3}\right) + \sin^2\left(\frac{2\pi x}{y_2}\right)}}$$

or

$$I_c = \sqrt{\frac{-k_t f_c \sin\left(\frac{2\pi x}{y_2} + \frac{2\pi}{3}\right)}{\sin^2\left(\frac{2\pi x}{y_2} + \frac{2\pi}{3}\right) + \sin^2\left(\frac{2\pi x}{y_2} - \frac{2\pi}{3}\right)}} \quad (4)$$

where f_a , f_b and f_c are the three-phase force inputs, x is the current position, y_2 is the pole pitch, and k_t is the force constant that can be calculated from the change of inductance value from unaligned to aligned position and the mechanical dimensions of the LSRM [3].

Traditionally, three independent current commands i_a , i_b and i_c defined in (4) will be tracked using three asymmetric bridge amplifiers. However, in this paper, another novel driving scheme is proposed such that the three independent phase commands can still be tracked using a standard three-phase bridge with only two current feedback sensors and two input commands.

IV. THREE-PHASE BRIDGE INVERTER FOR LSRM

In general, SRMs are driven by special inverters such as an asymmetric bridge, a unipolar converter and a C-Dump converter [1], [6], [7]. There was previously no interest in designing a SRM driver using a standard three-phase bridge [8], [9]. The advantages of using a standard three-phase bridge are the reduction in the size and cost of the motor driver, the reduction in stray inductance and EMI problem, and the direct compatibility to other three-phase motors. The dwell angle limitation in [8] is not suitable for the current tracking control in an accurate position control system. The inverter topology and the motor winding configuration employed in this paper are based on [9] with modifications on the phase current excitation sequence for the proposed LSRM.

Fig 4 shows a general three-phase bridge inverter for a three-phase linear/rotary PM/induction motor. The current loop controllers such as PI compensators are assumed to be appropriately designed or well-tuned so that the closed-loop bandwidth is adequate for an accurate current command tracking. As the summation current of a three phase system is equal to zero, i.e. $I_r + I_s + I_t = 0$, the control of three phase current is equivalent to the control of two phase currents, I_r and I_s , and the third current is slave to the other two as $I_t = -I_r - I_s$. Hence, only two current sensors are required for feedback purposes. However, the zero current summation assumption is not valid for SRM in general.

Electromechanical force generation in the LSRM is a function of the current magnitude only. By making use of this unipolar current driven feature, the LSRM can still be driven by the standard three-phase bridge inverter as shown in Fig. 4 with a proper motor winding reconfiguration. Firstly, the diode insertion in each phase is to guarantee unipolar current flowing, i.e. $I_a > 0$, $I_b > 0$ and $I_c > 0$. Secondly, the delta connection of the three-phase windings is to guarantee $I_r + I_s + I_t = 0$ with the current relations shown below:

$$I_r = I_a - I_c, I_s = I_b - I_a, I_t = I_c - I_b. \quad (5)$$

Finally, with (5), the magnitude of I_a , I_b and I_c can be independently controlled by two phase current I_r and I_s . The detailed excitation table is shown in Table III.

In summary, with the help of the delta motor windings reconfiguration, the insertion of the diodes and the two phase command current excitation table, the LSRM can be driven by a standard three-phase bridge with only two current sensors for

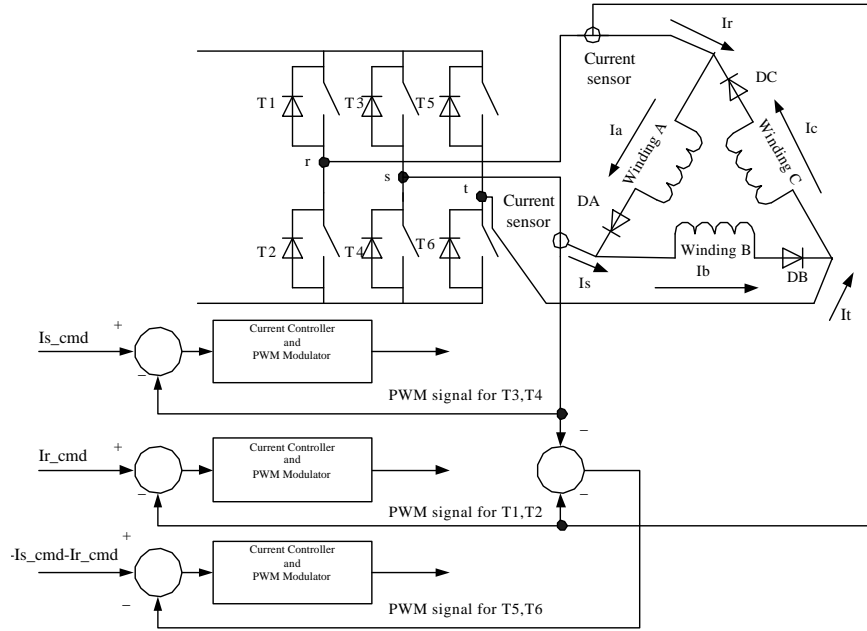

Fig. 4. Three-phase bridge inverter for LSRM.

TABLE III

CURRENT EXCITATION TABLE BY USING I_r AND I_s ONLY.

Region	For +ve force	For -ve force
1	$I_r = 0, I_s = I_b$	$I_r = I_a - I_c, I_s = -I_a$
2	$I_r = -I_c, I_s = I_b$	$I_r = I_a, I_s = -I_a$
3	$I_r = -I_c, I_s = 0$	$I_r = I_a, I_s = I_b - I_a$
4	$I_r = I_a - I_c, I_s = -I_a$	$I_r = 0, I_s = I_b$
5	$I_r = I_a, I_s = -I_a$	$I_r = -I_c, I_s = I_b$
6	$I_r = I_a, I_s = I_b - I_a$	$I_r = -I_c, I_s = 0$

feedback purposes. Hence, the proposed LSRM is now ready for connection to any general-purpose three-phase motor driver without any hardware change.

V. SYSTEM INTEGRATION AND EXPERIMENTAL RESULTS

The proposed LSRM system was tested using a standard AC servo system with a commercial motion controller, a current-tracking amplifier and a linear optical encoder. Fig. 6 and Fig. 5 show the block diagram of the whole LSRM

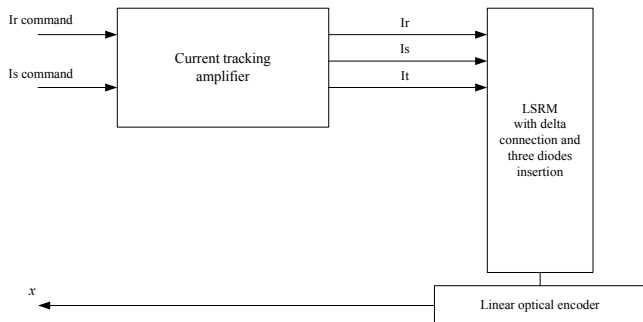

Fig. 5. Amplifier and LSRM setup.

system. In Fig. 6, the commercial motion controller is from ACS-Tech80 Inc. [12], and was responsible for the profile generation, standard velocity and position loop control with velocity and acceleration feed-forward. In addition, the motion controller was defined as a DC servo control axis with one DAC output and position encoder input. The proposed force linearization scheme defined in Table II, Table III and (4) was implemented by a dSPACE 1102 fast control prototyping system [13]. The inputs are the force command from the motion controller and the current position, while the outputs are two current commands for the current-tracking amplifier. It should be emphasised that there is no need to implement the force linearization algorithm for LSRMs by a separate DSP. If the low level DSP program of the motion controller can be accessed, the proposed algorithm can always be embedded within the same DSP, using look-up tables for the complex mathematical functions. The above experimental setup was just for the verification of the proposed algorithm.

Fig. 5 shows the experimental setup for the current-tracking amplifier, the LSRM and the linear optical encoder. The commercial current-tracking amplifier is from Copley Control Inc. [14] which accepts two input commands and provides three-phase output currents with the constraint $I_r + I_s + I_t = 0$. As described in Section IV, the LSRM is connected as a delta connection with three diodes insertion; therefore, a standard three phase bridge can still drive the proposed LSRM without any constraints.

To test the performance of the proposed system, a typical 20mm third order position profile with maximum acceleration = 0.4g and maximum velocity = 0.3m/s, was used as the test signal. Fig. 7 and 8 show the position error responses. Fig. 7 shows the position error for two cycles of profile tracking; it can be observed that the maximum

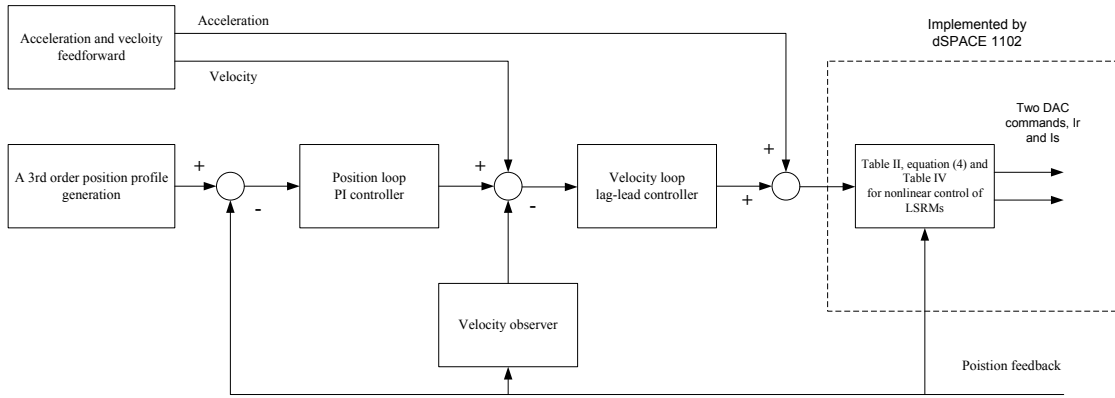

Fig. 6. Motion controller for the proposed system.

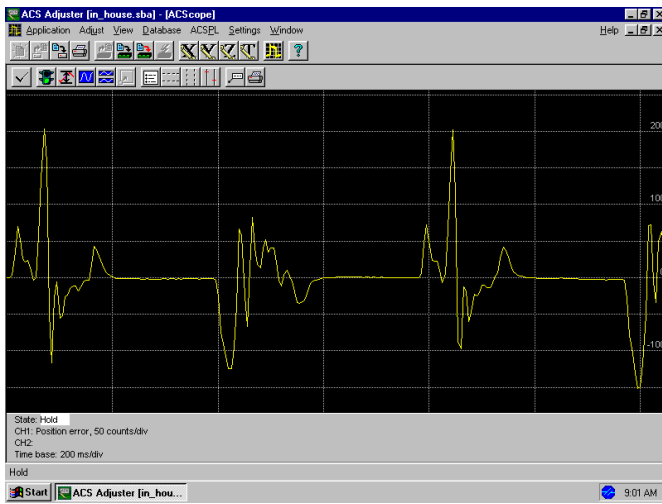

Fig. 7. Dynamic error position (y -axis: 50 counts per division).

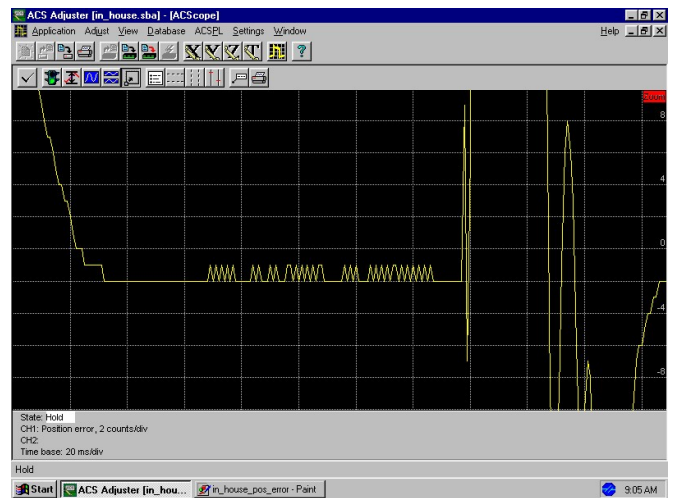

Fig. 8. Steady state error position (y -axis: 2 counts per division).

dynamic error is around 200 counts = $100\mu\text{m}$ (the resolution of the encoder used is $0.5\mu\text{m} = 1$ count). Furthermore, Fig. 8 shows the maximum steady state error of the position profile tracking, which is equal to 2 counts = $1\mu\text{m}$. The accurate position tracking response demonstrates the effectiveness of the proposed force linearization scheme.

The current tracking signals are also examined to verify the proposed driving scheme introduced in Section IV. Fig. 9 and Fig. 10 show respectively the current signals present at the amplifier phase terminal and the motor phase winding. A bipolar current signal can be found at the driver phase terminal as shown in Fig. 9 while a unipolar current is present at the motor winding due to the diode insertion. The captured waveforms show that the proposed driving scheme can drive an LSRM with a standard three-phase bridge and two current feedback sensors only. In summary, the promising experimental results show that the proposed LSRM system can be used as an accurate position tracking system.

VI. CONCLUSIONS

In this paper, a low-cost LSRM for position control application is designed, manufactured and verified. The developed

LSRM can be driven by a standard three-phase bridge inverter with the proposed driving scheme introduced in Section IV; therefore, the size of the overall driver can be reduced, the EMI problem can be alleviated and the cost of the whole system can be minimized. The feasibility and the effectiveness of the proposed position sensor and the inverter are supported by the experimental results shown in Section V.

In conclusion, the LSRM described in this paper is robust, reliable and low-cost. The proposed LSRM can work with the general-purpose three-phase motor controller without any hardware change. Therefore, this LSRM is a potential candidate for the replacement of linear three-phase PM/induction motors in special applications that require the features of magnet-free and high temperature operation. The popularity of applying LSRMs in industrial applications can definitely be promoted by the proposed system.

ACKNOWLEDGMENT

The authors would like to thank ASM Assembly Automation Hong Kong Ltd. for the support on this investigation.

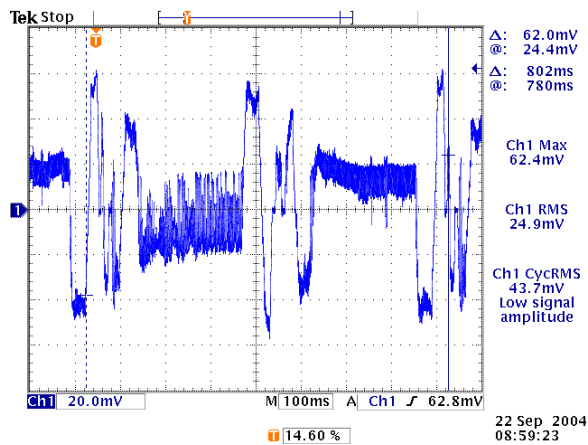

Fig. 9. Bipolar current signal at the driver phase terminal, I_r (10mv=1A).

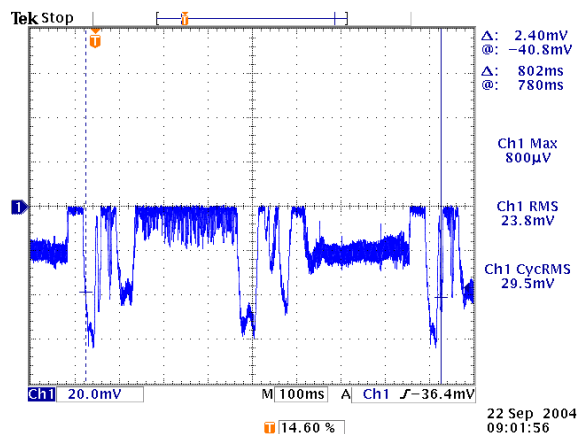
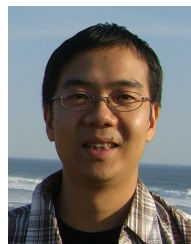

Fig. 10. Unipolar current signal at the motor phase winding, I_a (10mv=1A).

REFERENCES

- [1] T. J. E. Miller, *Switched Reluctance Motor and Their Control*, Oxford, 1993.
- [2] N. C. Cheung, "A robust and low-cost linear motion system for precision manufacturing automation," *IEEE Industry Applications Conference*, Vol. 1, pp. 40-45, Oct. 2000.
- [3] W. C. Gan and N. C. Cheung, "Design of a linear switched reluctance motor for high precision applications," *IEEE International Electric Machines and Drives Conference*, pp. 701-704, Jun. 2001.
- [4] W. C. Gan and N. C. Cheung, "Development and control of a low-cost linear variable-reluctance motor for precision manufacturing automation," *IEEE/ASME Trans. on Mechatronics*, Vol. 8, No. 3, pp. 326-333, Sep. 2003.
- [5] J. Corda and E. Skopljak, "Linear switched reluctance actuator," *Proc. of the Sixth International Conference on Electrical Machines and Drives*, Saint Nazaire, pp. 535-539, Sep. 1993.
- [6] C. Pollock and B. W. Williams, "A unipolar converter for a switched reluctance motor," *IEEE Trans. on Industrial Electronics*, Vol. 26, no. 2, pp. 222-228, 1990.
- [7] A. M. Hava, V. Blasko and T. A. Lipo, "A modified C-dump converter for variable-reluctance machines," *IEEE Trans. on Industrial Electronics*, Vol. 28, no. 5, pp. 1017-1022, 1992.
- [8] L. Xu and J. Bu, "Analysis of a novel converter topology for switched reluctance machine drives," *Proc. of the IEEE International Conference on Power Electronics, Drives & Energy Systems for Industrial Growth*, Vol. 2, pp. 640-645, 1998.

- [9] A. C. Clothier and B. C. Mecrow, "The use of three phase bridge inverters with switched reluctance drives," *Eighth International Conference on Electrical Machines and Drives*, pp. 351-355, 1997.
- [10] R. Krishnan, *Switched Reluctance Motor Drives: Modeling, Simulation, Analysis, Design, and Applications*, CRC Press, 2001.
- [11] F. Horrami, P. Krishnamurthy and H. Melkote, *Modeling and Adaptive Nonlinear Control of Electric Motors*, Springer-Verlag, 2003.
- [12] ACS-Tech80 website: <http://www.acs-tech80.com/>
- [13] dSPACE website: <http://www.dspace.com/>
- [14] Copley website: <http://www.copleycontrols.com/>



Wai-Chuen Gan received the B.Eng. degree (with first-class honors and the academic achievement award) in electronic engineering, and the M.Phil. and Ph.D. degrees in electrical and electronic engineering from Hong Kong University of Science and Technology, Clear Water Bay, Hong Kong, in 1995, 1997, and 2001, respectively. From 1997 to 1999, he was a Motion Control Application Engineer at ASM Assembly Automaton, Ltd., Hong Kong. He rejoined the same company in 2002 and is now a Staff Engineer in the R&D Motion group. He is a senior IEEE member and his current research interests include robust control of AC machines, power electronics, design and control of linear switched reluctance motors and linear permanent magnet motors.



G. P. Widdowson is a Chief Engineer at ASM Assembly Automation. He received his PhD in Electrical engineering from the Machines and Drives Group, University of Sheffield, UK, in 1992. He has authored and co-authored over 30 technical papers for journals and conferences and has 13 US patents in various fields of engineering. His academic interests include, motor design, sensor design, mechatronics and precision engineering.



power drives.

Michael S. W. Tam obtained his B.Eng degree from the Sunderland University in 1991. After his graduation, he worked in the High Power Manufacturer as an electronic engineer for two years and was responsible for the design of electronic ballast and UPS. He then joins the R&D motion group of ASM Assembly Automation company and is now a Principle Engineer and leading the motor driver group. He also got a master degree from The Hong Kong Polytechnic University in 2005. His research interests include DSP motion control systems and



Norbert C. Cheung received his BSc, MSc, and PhD from the University of London, University of Hong Kong, and University of New South Wales in 1981, 1987, and 1995 respectively. His research interests are motion control, actuators design, and power electronic drives. He is now an Assistant Professor in the Department of Electrical Engineering of the Hong Kong Polytechnic University.