

# Position Estimation in Solenoid Actuators

Muhammed Fazlur Rahman, *Senior Member, IEEE*, Norbert Chow Cheung, *Member, IEEE*, and Kiang Wee Lim, *Senior Member, IEEE*

**Abstract**—This paper describes a novel method of estimating the position of a plunger inside a solenoid. The solenoid is a single-phase variable reluctance actuator, with a highly nonlinear magnetic circuit. For the proposed method, position is estimated indirectly through the solenoid's incremental inductance in the high current region. It exploits the advantage that motional electromotive force (EMF) is negligible under normal operating condition. The incremental inductance is obtained from the rate of current rise of the pulse-width modulated (PWM) waveform, which in turn, is measured by a dedicated current rise measurement circuit. Position is estimated from a two dimensional look up table of incremental inductance and current. The method is simulated and then implemented on a typical industrial solenoid valve. Factors which affect the accuracy of the estimation and methods of overcoming them are also described in the paper.

## I. INTRODUCTION

**S**OLENOIDS are widely used as switching actuators. They are simple in construction, rugged, and relatively cheap to produce. For these reasons they can be found in many industrial and domestic apparatus in which limited stroke, on-off mechanical movements are required. Solenoids are normally used in the form of electrical contactors in relays, fluid-gas valves, and switching linear-rotary motional devices. On the other hand, conventional proportional actuators are high-precision, limited travel motional devices, driven by step motors, moving coil actuators, or other motors with a linear control characteristic. Such proportional actuators are more complex in construction, contain delicate moving and sensing elements, and are expensive to produce and maintain. These actuators are used in high-end applications in which precise control over the movements of the actuator is required. Examples of applications include fluid flow control in hydraulic servo systems, grasping motions in robot fingers, robot joints, positioning systems, machine tool drives, etc.

This paper describes part of a project which aims to convert switching solenoids into proportional actuators by the use of intelligent control. The project is motivated by the following three considerations. First, the production cost of solenoids is much lower than traditional proportional actuators. Secondly, solenoids have simple constructions, and are therefore more

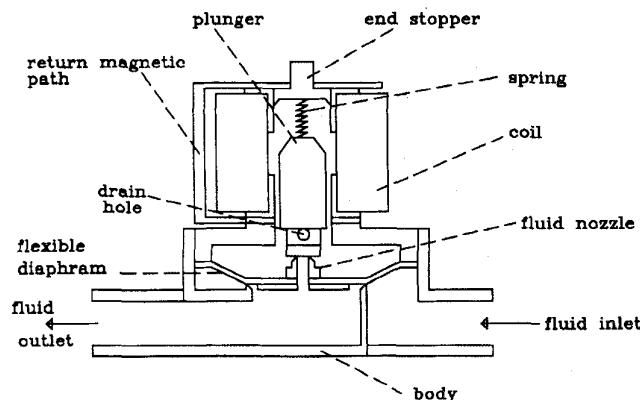

Fig. 1. Construction of a two-stage solenoid valve.

robust and maintenance free. Finally, solenoids can be easily incorporated into systems design due to their compact size.

Conversion of a solenoid into a proportional actuator has been successfully accomplished and is reported in [1] and [2]. The next research stage is to eliminate the position sensor inside the proportional solenoid, so that a more robust and lower cost proportional actuator can be constructed. Fig. 1 is a typical construction of a two-stage solenoid valve. The total travel of the plunger is very short, in most cases it is below 1 centimeter. Since fluid flows all around the plunger, and the area is totally sealed, there is little space to mount a position sensor inside the solenoid. Therefore sensorless position detection is a very attractive proposition.

Presently, there is much research work done on sensorless position estimation on rotary variable reluctance machines. Unfortunately, none of these methods are suitable for use in solenoid actuators. Some methods can only work on multiphase machines, because they require an inactive phase for signal injection [3] or inductance measurement at near zero current level [4]. Other methods require continuous integration to calculate flux linkage [5], [6]. However, these methods are only suitable for cyclic electrical signals, as in rotary machines, because offset error can be compensated easily. Unidirectional electrical signals, as in the case of solenoids, cannot be compensated readily and will cause integration runaway problems. Recently, there has been much work done on position estimation based on observer principles [6]. However, solenoids' control characteristics are highly nonlinear and complex to model [7]. Also, mechanical loads of solenoids vary greatly with external factors, and are difficult to predict and model. To implement a nonlinear position observer

Paper 95-75, approved by the Electric Machines Committee of the IEEE Industry Applications Society for presentation at the 1995 Industry Applications Society Annual Meeting, Lake Buena Vista, FL, October 8-12. Manuscript released for publication November 6, 1995.

The authors are with the School of Electrical Engineering, University of New South Wales, Sydney 2052, Australia.

Publisher Item Identifier S 0093-9994(96)02672-2.

based on the solenoid's complex control model is not practical and is unreliable.

This paper proposes a new method to estimate the position of the solenoid by obtaining its incremental inductance in the high-current region.

The method exploits the advantage that motional electromotive force (EMF) of a solenoid under normal operating condition is negligible. Due to this, the incremental inductance can be estimated accurately from the voltage, current, and the rate of current rise of the pulse-width modulated (PWM) waveform. A novel hardware circuit is implemented to measure the rate of current rise accurately.

## II. THE PROPOSED METHOD

### A. Model of the Solenoid

To develop a sensorless position estimation method for the solenoid actuator, the first step is to investigate the control characteristics of the device. A dynamic model for such a solenoid has been presented in [7]. In this section, the model is briefly reviewed.

The voltage applied to the solenoid coil,  $V$ , is

$$V = Ri + \frac{d\lambda}{dt} \quad (1)$$

where  $i$  is the current,  $R$  is the resistance of the coil, and  $\lambda$  is the flux linkage of the coil. The flux linkage  $\lambda$  is dependent on the current of the coil and the air gap distance  $x$ . Equation (1) can be expanded as

$$V = Ri + \left( L_e + \frac{\partial \lambda}{\partial i} \right) \cdot \frac{di}{dt} + \frac{\partial \lambda(x, i)}{\partial x} \cdot \frac{dx}{dt} \quad (2)$$

where an external inductance term  $L_e$  represents the flux leakage. On the mechanical side, the solenoid is represented by a second-order linear system:

$$m_p \ddot{x} = F - K_s x - F_d \quad (3)$$

where  $m_p$  is the mass of the plunger,  $K_s$  is the spring constant,  $F$  is the force produced by the magnetic field,  $x$  is the displacement of the plunger, and  $F_d$  is a load force which may include the gravitational force.

The force produced by the magnetic field can be calculated from the coenergy  $W'$  [8] where

$$F = \frac{\partial W'(x, i)}{\partial x} \quad \text{and} \quad W'(x, i) = \int_0^i \lambda(x, i) di. \quad (4)$$

From (4), the instantaneous value of force  $F$  can be rewritten as

$$F = \frac{\partial \lambda(x, i)}{\partial x} \cdot i. \quad (5)$$

Flux linkage has a nonlinear relationship with current and with position. These relationships can be obtained experimentally [8] and are of the form shown in Fig. 2.

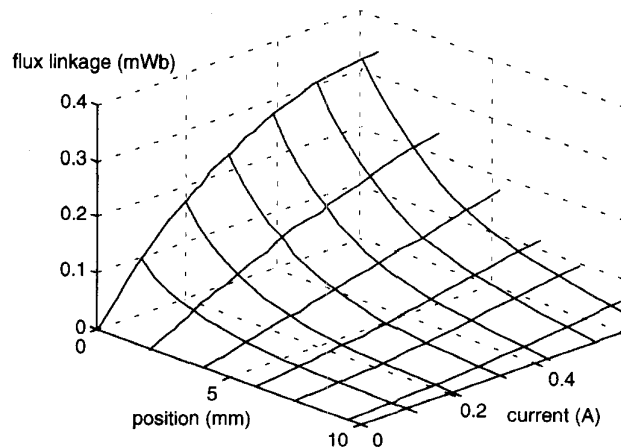

Fig. 2. The three-dimensional nonlinear relationship of flux linkage against current and position of the solenoid.

From (1)–(5), a set of state equations can be formed:

$$\frac{dx}{dt} = v \quad (6)$$

$$\frac{dv}{dt} = (F - K_s x - m_p g) \cdot m_p^{-1} \quad (7)$$

$$\frac{di}{dt} = \left( V - Ri - E(x, i) \cdot \frac{dx}{dt} \right) \cdot L(x, i)^{-1} \quad (8)$$

where

$$E(x, i) = \frac{\partial \lambda(x, i)}{\partial x} \quad \text{and} \quad L(x, i) = L_e + \frac{\partial \lambda(x, i)}{\partial i}$$

### B. Calculation of the Incremental Inductance

Equations (6) and (7) describe the mechanical dynamics of the solenoid, while (8) is the solenoid's voltage equation. External loading of a solenoid is large and unpredictable, and it affects the mechanical dynamics of a solenoid significantly. Therefore (6) and (7) do not provide an accurate and predictable description on the position of the solenoid. In the proposed method, only (8) is used for position estimation. Equation (8) is rearranged into the following form:

$$L(x, i) = \frac{V - Ri - E(x, i) \frac{dx}{dt}}{\frac{di}{dt}}. \quad (9)$$

Equation (9) is meaningful if  $di/dt$  is nonzero and significantly large. For the case of a proportional solenoid, there are times when the plunger is stationary and the current change is zero. To resolve this,  $di/dt$  is measured from the current ripple of the PWM chopping waveform, instead of obtaining  $di/dt$  from the average current waveform.

Since the positive chopping voltage is much higher than the maximum operating voltage of the solenoid [1], [2],  $di/dt$  is always significant and nonzero. Fig. 3 is a diagram showing the concept of  $di/dt$  measurement from a PWM waveform.

Another term which needs to be resolved is the motional EMF  $E(dx/dt)$ . If the speed of the plunger is low, this term becomes insignificant, and may be eliminated from (9).

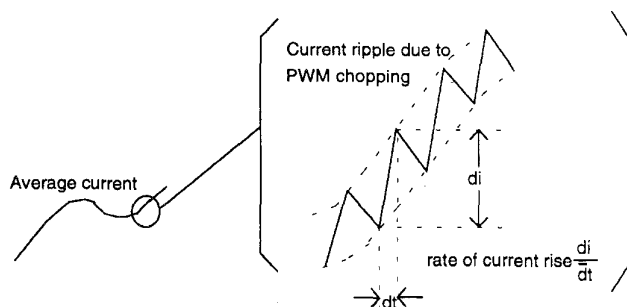

Fig. 3. Measuring  $di/dt$  from a PWM current waveform.

To investigate the significance of motional EMF in relation to other terms in (9), a simulation of normal operation of the proportional solenoid is carried out, and the values of  $E(dx/dt)$  and  $V - Ri$  are recorded. Models of the proportional solenoid, the nonlinear controller and the power electronics, and the simulation process has been described in [2]. In the simulation, a sawtooth trajectory with a peak to peak travel of 1–6 mm and period of 1 s has been chosen. Fig. 4 is the result of this simulation. Fig. 4(a) is the magnitude of  $V - Ri$ , while Fig. 4(b) shows the magnitude of the motional EMF. The plots indicate that, for normal operation of a proportional solenoid, motional EMF contributes less than 2% of its value in relation to the overall equation, under worst case situation. Therefore the motional EMF term is insignificant. Elimination of this term will not add significant error to the estimation of incremental inductance. As a result (9) can be simplified to (10), and the incremental inductance  $L(x, i)$  can be calculated from the electrical values of  $V, i$ , and  $di/dt$ .

$$L(x, i) = (V - Ri) \left( \frac{di}{dt} \right)^{-1}. \quad (10)$$

Hardware implementation of the proportional solenoid has also been carried out to confirm that the simulation result is an accurate description of the actual process.

### C. Relationship Between Incremental Inductance and Position in a Solenoid

The incremental inductance value is dependent on the variables of  $x$  and  $i$ . Therefore, it is possible to estimate the position of the plunger from current and incremental inductance values. However, this is only true if  $x$  and  $i$  have a monotonic reference with  $L$ . To investigate this matter further, incremental inductance values of a typical industrial solenoid are measured against different currents and positions. This is done by measuring  $V, i$ , and  $di/dt$  values of the solenoid, and calculating  $L$  from (10).  $di/dt$  values are measured by a dedicated current rise measurement circuit, which is described in the implementation section of this paper.

Alternatively, incremental inductance can be calculated from (8) and the flux linkage data in Fig. 2. However, this method requires the measurement of leakage inductance  $L_e$  and the manipulation of a large amount of magnetic data.

Fig. 5 is the plot of incremental inductance versus position at various current levels. At low-level currents of 0–0.1

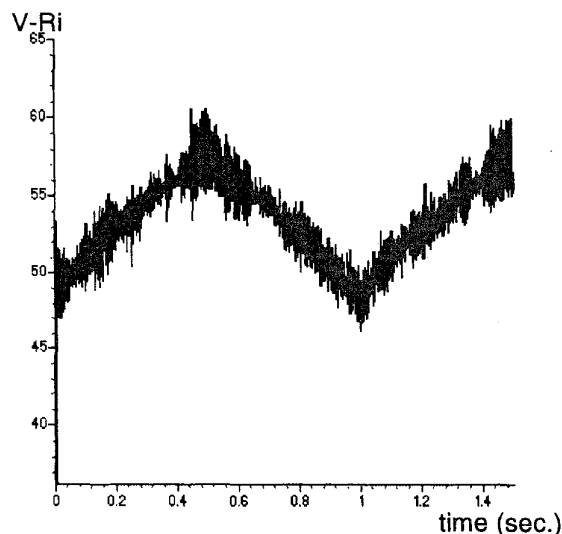

(a)

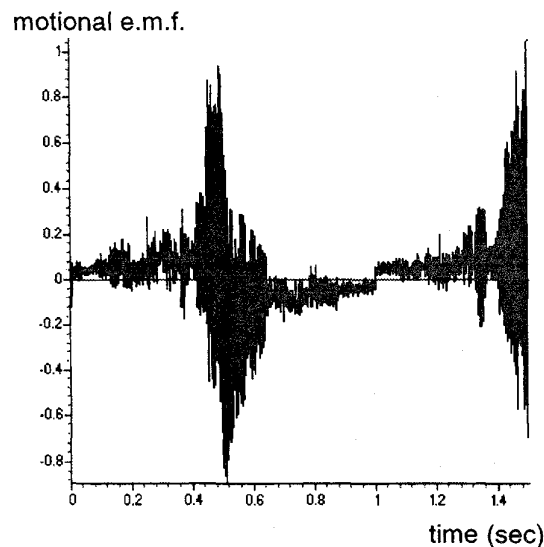

(b)

Fig. 4. Simulation on the operation of the proportional solenoid. (a) Plots of  $V - Ri$  versus time. (b) Plots of motional EMF versus time.

A, inductance decreases substantially as air gap position is increased. However, when current level is increased, the rate of current decrease is reduced. As current is increased to 0.2 A or above, saturation occurs, and  $L$  behaves differently.

In the high-current region, as the plunger position increases, the inductance increases accordingly, then at a certain point, decreases again due to saturation. Also, the change of inductance is not as substantial as at the low-current region. Therefore, position estimation in this region is much more difficult than the low-current region of 0–0.1 A. The proportional solenoid normally operates at a high-current region of 0.2–0.6 A [1], [2]. To ensure that the estimation process provides acceptable accuracy, attention must be paid to the precise measurements of electrical quantities, particularly the  $di/dt$

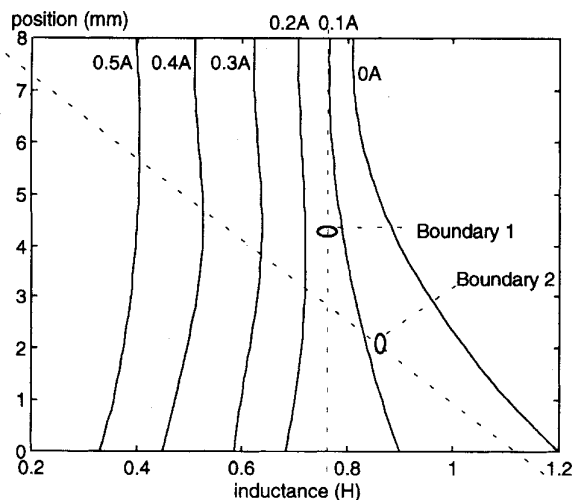

Fig. 5. Variation of incremental inductance with position at different levels.

values. On top of this, some position-inductance plots do not give unique position values. To overcome this, boundaries are drawn on the position-inductance table to confine the operation of position estimation within its boundaries.

Essentially, two boundaries are used to mark out the area which is suitable for position estimation. As shown in Fig. 5, boundary 1 divides the operation of a solenoid into saturation (high-current) and nonsaturation (low-current) regions. The nonsaturated region is only useful for position estimation of multiphase variable reluctance (VR) motors, when an unenergized phase is available. For the proportional solenoid, normal operation occurs in the saturated region. Boundary 2 is used to restrict the operation of position, so that unique position estimations can be obtained from current and inductance inputs. Position estimation is restricted to the area below boundary 2. Combining the two boundaries, position estimation is restricted to the lower left portion of Fig. 5.

Due to these restrictions, position estimation for a solenoid actuator is limited to 1–6 mm of plunger travel. Although position estimation does not work when position is large (e.g., 6 mm) and current is small (e.g., 0.2 A), this situation never occurs because the solenoid has a nonlinear force-current characteristic; high current is required to drive the plunger when the air gap distance is large. On the other hand, when air gap is small (0–1 mm), very low level currents (<0.2 A) is needed to control the plunger. Under this situation, the operation of the solenoid will cross over from saturation region to nonsaturation region. Therefore this region is also prohibited. Although the solenoid can be operated with a stroke length of 5 mm (i.e., 1–6 mm) only, it is already very useful, and can readily cope with many industrial applications.

### III. SIMULATION OF THE POSITION ESTIMATION SCHEME

#### A. The Simulation Process

A simulation study of the proposed position estimation process is carried out prior to hardware implementation. The solenoid, proportional controller, power electronics,  $di/dt$

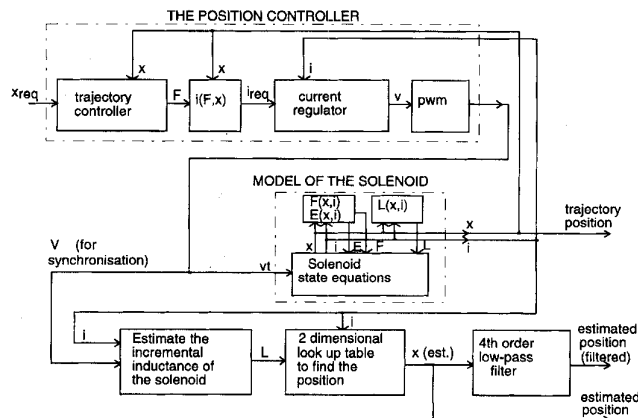

Fig. 6. Simulation of a proportional solenoid and the position estimation process.

capture circuit, and the position estimation process are all included in the simulation process. The overall simulation block diagram is shown in Fig. 6. A nonlinear system simulation package (SIMNON) is used for the simulation of the position estimation process and the proportional control scheme.

Details on the construction of the solenoid's model and the proportional controller have been described in [2]. For the position estimation simulation, a position estimation block and a filter block is added to the original proportional solenoid simulation model. The model simulates the operation of a solenoid under trajectory following mode. A sawtooth waveform with a period of 1 s is used as reference position input.

The model includes magnetic nonlinearities, saturation, flux leakage, quantization noise, sampling effects, and PWM chopping. However, the simulation process does not include hysteresis, stability of the power supply, and change of coil resistance. The simulation also assumes that the model is accurate and tolerance free.

#### B. Results of Simulation

Initial results of simulation reveals that substantial noise is present in the estimated position output. It is particularly significant when the air gap distance is large. The main reason is because of the low gradient profile of the inductance-position characteristics, especially when the air gap distance is large. To reduce the noise content, a fourth order low pass filter is added to the estimation process, as shown in Fig. 6. Since the resonant frequency of the plunger is less than 80 Hz, a fourth-order low-pass filter with a cut off frequency of 150 Hz is added to the output stage.

Result of the position estimation, after passing through the filter block is shown in Fig. 7. The noise is much reduced, and the filtered output gives a much better position estimation. Phase delay due to filtering is insignificant. The simulation result confirms that position estimation through incremental inductance is a feasible solution.

The simulation results show that position estimation is accurate even when motional EMF is ignored from the estimation process. On the other hand, results from simulation shows that the position output is noisy and a low-pass filter is required

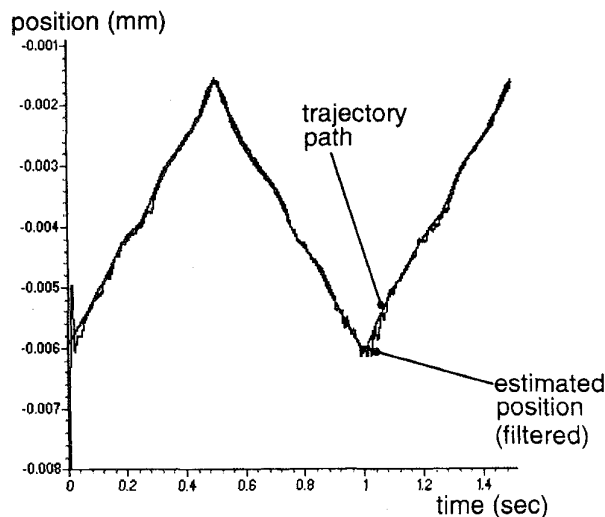

Fig. 7. Simulation of the position estimation process.

to produce acceptable results. This occurs under the situation when perfect modeling accuracy is assumed. For the actual implementation of this scheme, when the modeling of the solenoid is not perfect, and when other undesirable features exist, position estimation will be less ideal.

#### IV. HARDWARE IMPLEMENTATION

##### A. The Overall Hardware Setup

The overall structure of the experimental setup is shown in Fig. 8. Basically it is a proportional solenoid controller plus a dedicated current rise measurement circuit to capture the  $di/dt$  values. In the experiment, the digital signal processor (DSP) uses the values of  $V$ ,  $i$ , and  $di/dt$  to estimate position in real time. The estimated position, together with the actual position are recorded in a trace module for further analysis. Apart from position estimation, the DSP also executes the nonlinear proportional control scheme concurrently and in real time.

##### B. Measuring $di/dt$

The success of the proposed position estimation scheme depends heavily on accurate measurement of  $di/dt$ . There is little in recent literature which provides a reliable and accurate solution to measure  $di/dt$  for PWM waveforms. Acarnley *et al.* [9] determines the current rise of a chopping waveform by measuring the frequency of the hysteresis current controller. However, the method is unsuitable for fixed-frequency PWM output with a sophisticated current control strategy, as in the case of proportional solenoid. Panda *et al.* [10] has suggested a hardware circuit to detect the current rise of a fixed-frequency PWM waveform, but the method is not suitable for continuous position estimation. Kulkarni *et al.* [11] has suggested a position estimation scheme for permanent magnet synchronous motors by measuring its  $di/dt$  values, but there is no indication on how this method can be implemented in practice, particularly in measuring  $di/dt$ . Only the simulation result is published.

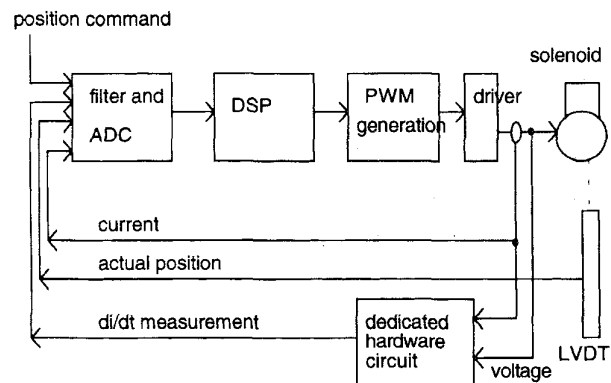

Fig. 8. Setup of the position estimation experiment.

The main difficulties for  $di/dt$  capture are i) the processing of high-frequency PWM, ii) the synchronization of high-frequency waveforms, iii) the relatively small magnitude of  $di/dt$  when compared to the absolute current value, and iv) the noise associated with measuring differential signals.

In this paper, a dedicated circuit to measure the current rise of the PWM waveform is developed and implemented. The hardware removes the current offset and brings the initial current rise measurement potential to zero. It synchronizes the current capture time with the PWM waveform. Finally, it sums up a number of current rise waveforms during a number of PWM periods, so that the total current rise during a predefined sampling time is obtained. In this way, measurement of  $di/dt$  becomes more accurate and noise free.

The block diagram of the current rise measurement circuit is shown in Fig. 9. The circuit is a combination of four separate functional blocks: offset elimination, summation and capture, timer and synchronization, and handshake. The offset elimination block amplifies the current signal, samples its reference points, then brings the reference points down to zero. In this way, offset current is eliminated. The circuit uses the positive PWM cycle for current rise capture. The summation and capture block sums up the total current rise during a specific period of time determined by the timing block. By adding all the current rise waveforms within a specific time frame and by obtaining the average value of current rise, accuracy is increased and noise is reduced.

The timing and synchronization block synchronizes the current rise capture process with the PWM voltage. The timing of the current rise measurement is regulated by an integrator. The handshake block ensures that the captured output can be transferred to the DSP reliably. A standard two-line handshake protocol is used.

Fig. 9 is the block diagram of the current rise measurement circuit, and Fig. 10 shows the waveforms at different parts of the circuit.

##### C. Construction of the Two-Dimensional (2-D) Look-Up Table

A two-dimensional look-up table is required to translate values of incremental inductance and current into position. Graphical representation of the look up table is given in Fig. 11. The shaded area in the top right hand corner of the

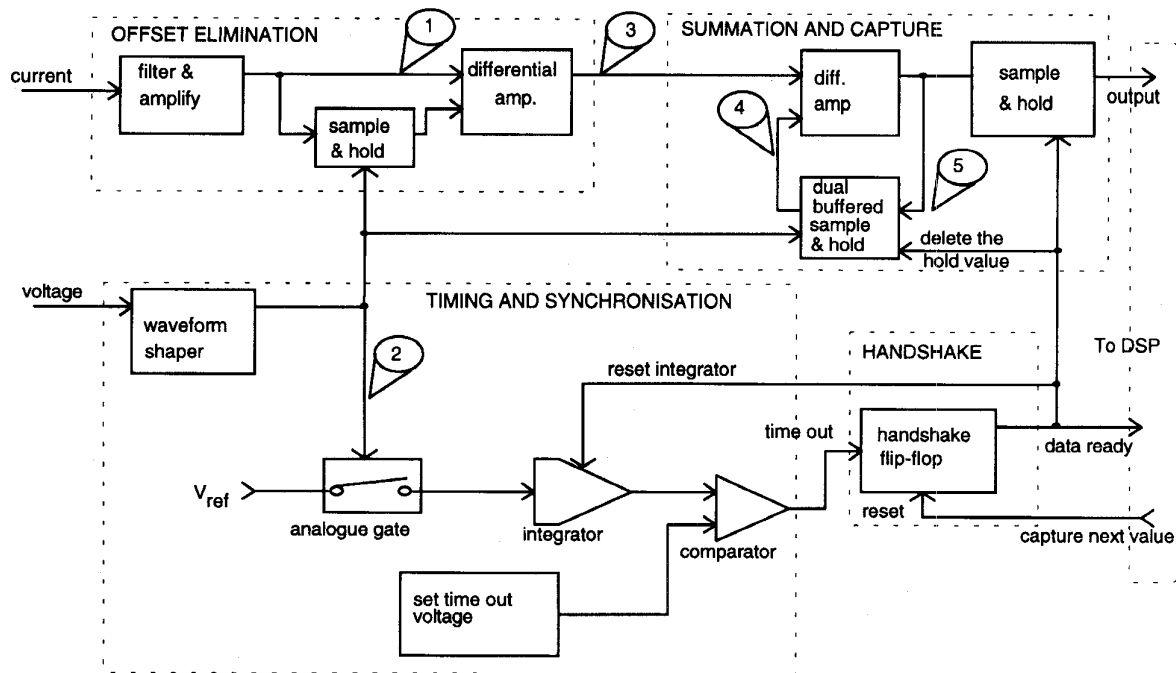

Fig. 9. Block diagram of the current rise measurement circuit.

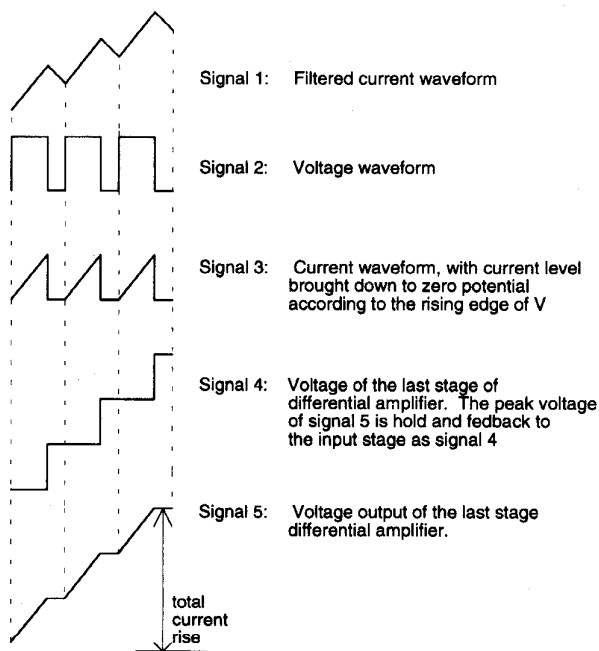

Fig. 10. Waveforms at different parts of the current measurement circuit.

graph is unsuitable for position estimation. The table size is  $50 \times 50$ , and bilinear interpolation is used to calculate the intermediate values.

V. RESULTS

Fig. 12 is the result of position estimation when implemented in hardware. The trajectory path of the plunger and the estimated position are both shown in the same graph. In

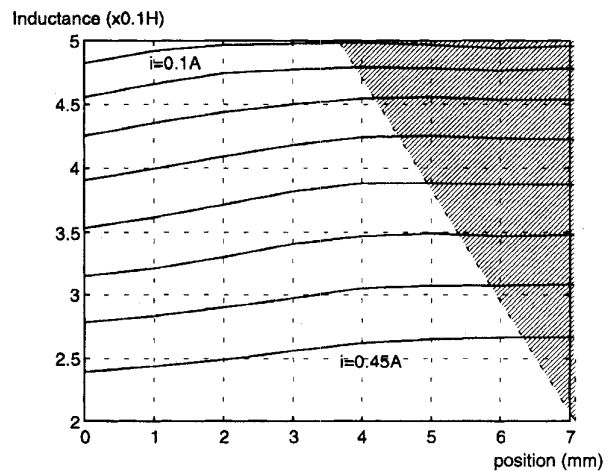

Fig. 11. Graphical representation of the position-inductance-current look-up table.

the experiment, a triangular waveform with a period of 1 s and a peak-to-peak travel of 1–6 mm is used as the input command for the proportional controller.

Overall, the estimated position resembles the trajectory path. The estimated position is noisy around the 5–6-mm region. This is due inadequate variation of incremental inductance with position in that region. Although hysteresis does not cause significant reduction in accuracy, its does have an effect on the estimated position when a large change in current direction occurs. It causes a “kick” in the estimated position. Change of resistance due to temperature rise will also affect the accuracy of position estimation. It has an effect of slightly shifting the estimated position curve upwards or downwards. However, this effect can easily be compensated

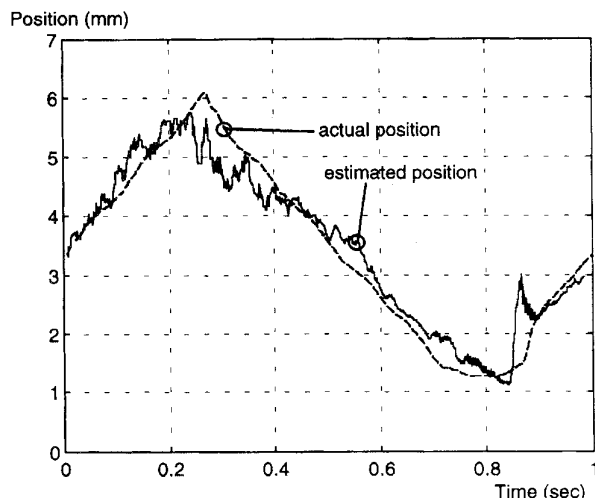

Fig. 12. Result of position estimation.

by periodic calculation of actual resistance during static or slowly moving voltage and current waveforms. Unlike speed controlled variable reluctance motors, a position-controlled proportional solenoid experience many periods of near-static current and voltage waveforms during its operation.

Although the present result of position estimation still contains a small amount of noise and there are limitations on the position estimation range, it is already very useful for low-resolution position estimation, especially when the solenoid operates as a valve, and the plunger is totally immersed in fluid.

## VI. CONCLUSION

Compared to speed-controlled multiphase variable reluctance motors, position estimation in proportional solenoid is much more difficult. This is due to its single-phase structure, noncyclic electrical signals, unpredictable load variations, highly nonlinear model, and the lack of position information in the voltage equation. Hysteresis and low position-inductance gradient also add to the difficulty of position estimation. This paper solves the position estimation problem through detailed investigation into the control model of the proportional solenoid, and locates the part of the model in which position estimation is most appropriate. It then proposes to estimate position indirectly through incremental inductance, exploiting the fact that motional EMF is insignificant under normal operation conditions. Simulation on the position estimation of proportional solenoid confirms that the proposed method is feasible, although there is a little noise in the large air gap region. For the actual implementation, the estimation process is implemented on a DSP and computed in real time. A reliable and accurate way of measuring  $di/dt$  has been developed and the concept has been implemented in hardware.

Results of hardware implementation shows that the estimated position resembles the actual position trajectory, although the result is slightly noisy. In spite of this, it is already very useful for low-resolution position estimation of solenoids, especially in cases when mounting of the position sensor is not

feasible. This method is suitable for any slow-moving single-phase variable reluctance motion device; the computation overhead is low, and the additional hardware can easily be condensed onto a programmable cell array chip. On the other hand, the accuracy of position estimation is dependent on the inductance-position-current characteristics of the device. Generally a device with a higher inductance-position gradient gives better estimation result.

## APPENDIX

Specifications of the solenoid actuator:

Make:	Goyen Controls
Model:	20BW2 DC
Type:	Two stage, switching solenoid valve
Stroke length:	10 mm
Operating voltage:	24 V d.c.
Maximum current:	0.6 A
Resistance:	40 $\Omega$ at room temperature
Inductance:	0.35–1.1 H
no. of turns of coil:	2240 T

## ACKNOWLEDGMENT

The authors would like to thank Goyen Controls Co. Pty. Ltd. of Milperra, Sydney, for providing the samples and technical information on the solenoids.

## REFERENCES

- [1] K. W. Lim, N. C. Cheung and M. F. Rahman, "Proportional control of a solenoid actuator," in *IEEE Proc. Ind. Electron. Soc. Annu. Meeting, IECON'94*, Bologna, Italy, vol. 3, pp. 2045–2050, Sept., 1994.
- [2] ———, "Conversion of a switching solenoid to a proportional actuator," in *IEEE Proc. Int. Power Electron. Conf., IPEC'95*, Yokohama, Japan, vol. 3, pp. 1628–1633, Apr., 1995.
- [3] M. Eshani and A. B. Kulkarni, "Elimination of discrete position and current sensor in switched reluctance motor drives," *IEEE Trans. Ind. Applicat.*, vol. 28, no. 1, pp. 128–135, Jan./Feb., 1992.
- [4] S. R. MacMinn, P. M. Szczyzny, W. J. Rzesos, and T. M. Jahns, "Application of sensor integration techniques to switched reluctance motor drives," *IEEE Trans. Ind. Applicat.*, vol. 28, pp. 1339–1344, Nov./Dec., 1992.
- [5] J. P. Lyons, S. R. MacMinn, and M. A. Preston, "Flux/current method for SRM rotor position estimation," in *IEEE Proc. Ind. Applicat. Soc. Annu. Meeting*, vol. 1, pp. 482–487, 1991.
- [6] R. Lagerquist, I. Boldea, and T. J. E. Miller, "Sensorless control of synchronous reluctance motor," *IEEE Trans. Ind. Applicat.*, vol. 30, no. 3, pp. 673–682, May/June, 1994.
- [7] N. C. Cheung, K. W. Lim, and M. F. Rahman, "Modeling a linear and limited travel solenoid," in *IEEE Proc. Ind. Electron. Soc. Annu. Meeting, IECON'93*, Hawaii, vol. 3, pp. 1555–1563, Nov., 1993.
- [8] ———, "Simulations and experimental studies toward the development of a proportional solenoid," in *Proc. Australian Universities Power Eng. Conf., AUPEC'93*, Wollongong, Australia, vol. 2, pp. 582–587, Sept., 1993.
- [9] P. P. Acarnley, C. W. Hooper, and R. J. Hill, "Detection of rotor position in stepping and switched reluctance motors by monitoring of current waveforms," *IEEE Trans. Ind. Electron.*, vol. 32, no. 3, pp. 215–222, Aug., 1985.
- [10] S. K. Panda and G. A. J. Amarantunga, "Analysis of the waveform detection technique for indirect rotor position sensing of switched reluctance motor drives," *IEEE Trans. Energy Conversion*, vol. 6, no. 3, pp. 476–483, Sept., 1991.
- [11] A. B. Kulkarni and M. Eshani, "A novel position sensor position elimination technique for interior permanent-magnet synchronous motor drive," *IEEE Trans. Ind. Applicat.*, vol. 28, no. 1, pp. 144–150, Jan./Feb., 1992.

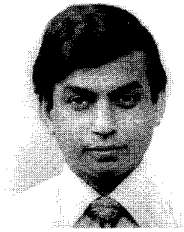

**Muhammed Fazlur Rahman** (M'79-SM'88) graduated in electrical engineering in 1972 from the Bangladesh University of Engineering and Technology. He received M.S. and Ph.D. degrees from University of Manchester, U.K., in 1975 and 1978, respectively.

He subsequently worked as a Systems Design Engineer at the General Electric Projects Company of U.K. at Rugby for two years before joining the National University of Singapore in 1980. He joined the University of New South Wales, Sydney, Australia, in 1988 as a Senior Lecturer. His research interests are in power electronics, motor control and motion control systems.

Dr. Rahman is a member of IEEE Societies of Power Electronics, Industry Applications, and Industrial Electronics.



**Khiang Wee Lim** (M'83-SM'92) graduated from the University of Malaya and Oxford University with B.Eng and D.Phil. degrees, respectively.

He is currently an Associate Professor at the University of New South Wales in Sydney, Australia. His current research projects are in the control of motors and in the theory of multi-rate systems.

Dr. Lim is a member of the Administrative Committee of the IEEE Industrial Electronics Society.

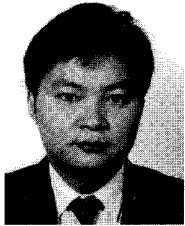

**Norbert Chow Cheung** (M'91) obtained B.Sc.(Eng) and M.S. degrees from the Universities of Hong Kong and London, respectively, in 1981 and 1987. From 1992 to 1995, he studied for the Ph.D. degree at the University of New South Wales, Sydney, Australia.

From 1982 to 1985, he worked at the General Electric (Hong Kong) and the Productivity Council of Hong Kong, specializing in the development of industrial controllers NC servo systems. From 1985 to 1992, he worked as a lecturer and a senior lecturer in electrical engineering at the Hong Kong Polytechnic. His research interests include motion control, drives and computer applications in industrial automation.

Dr. Cheung is a Chartered Engineer and is a member of the IEEE Industry Applications and Industrial Electronics Societies.