

# Study of Art of Automotive Active Suspensions

X. D. Xue, K. W. E. Cheng, Z. Zhang, J. K. Lin, D. H. Wang, Y. J. Bao, M. K. Wong, and N. Cheung

Department of Electrical Engineering, The Hong Kong Polytechnic University, Hong Kong  
E-mail: eexdxue@polyu.edu.hk, eeecheng@polyu.edu.hk, 09900854r@polyu.edu.hk, 09901316r@polyu.edu.hk, eedhwang@polyu.edu.hk, eeyjbao@polyu.edu.hk, eemkwong@polyu.edu.hk, and norbert.cheung@polyu.edu.hk

**Abstract**—In this study, research and development of automotive active suspensions are reviewed. Structures and models of various automotive suspensions are described. Furthermore, typical commercial products of automotive suspensions are illustrated. Based on the reported studies and development, the authors discuss the comparisons between various vehicular suspensions from the aspects of structure, weight, cost, ride comfort, handling performance, reliability, dynamic performance, energy recovery, and commercial maturity. Consequently, it is deduced that electromagnetic active suspensions are the future trend of automotive suspensions due to simple structure, high-bandwidth, accurate and flexible force control, high ride quality, good handling performance, and energy regeneration. At the same time, the issues of future research and development of electromagnetic active suspensions are proposed.

**Keywords**—Active suspensions, actuators, vehicles.

## I. INTRODUCTION

An automotive suspension system is one of the important components in a vehicle. In general, a suspension system consists of four suspensions in four-wheel vehicles, where a suspension is equipped at a wheel. Within the available suspension travel, aims of a vehicular suspension are: (a) to isolate the vehicle body from external disturbances coming from irregular road surfaces and internal disturbances created by cornering, acceleration, or deceleration, in order to have ride comfort; (b) to carry the weight of the vehicle body; (c) to react to variations in load, which are whether generated by changes in the number of passengers and luggage, or from internal disturbances; and (d) to keep a firm contact between the road and the tires, in order to have good handling performance that means drive safety. It can be seen that safety and ride comfort characteristics of a vehicle mainly depend on the suspension system [1]-[3]. Thereby, research and development of vehicular suspensions have been being concerned, in order to meet human stronger and stronger requirements on ride quality and drive safety.

This study focuses on the art of automotive active suspensions. The organization of this paper is given as follows: first, the section II describes the classification and models of automotive suspensions; in the section III, next, reported research and development of hydraulic or pneumatic active suspensions are reviewed; then, reported investigations on electromagnetic active suspensions are discussed in the section IV; in the section V, after that, the comparisons between various automotive suspensions are

shown; and finally, the conclusion is given in the section VI.

## II. CLASSIFICATION OF AUTOMOTIVE SUSPENSIONS

In this study, automotive suspensions are classified into three types, which are passive, semi-active, and active suspensions.

### 1. Passive Suspensions

A passive suspension is a conventional system which is composed of the non-controlled spring and the shock-absorbing damper. Both components work mechanically in parallel and are fixed between the wheel supporting structure (unsprung mass) and the vehicle body (sprung mass). The damper is a cylinder filled with hydraulic oil or compressed gas. Inside the cylinder there is a piston driven by a rod. Furthermore, the fluid or gas may pass between the components inside the cylinder. This fluid or gas flow generates a reaction force that is proportional to the relative speed between sprung and unsprung masses. The damping is achieved by converting the energy of the oscillations in heat [4]. The profile of a commercial passive suspension is shown in Fig. 1a [5] and the quarter-car model of a passive suspension are illustrated in Fig. 1b.

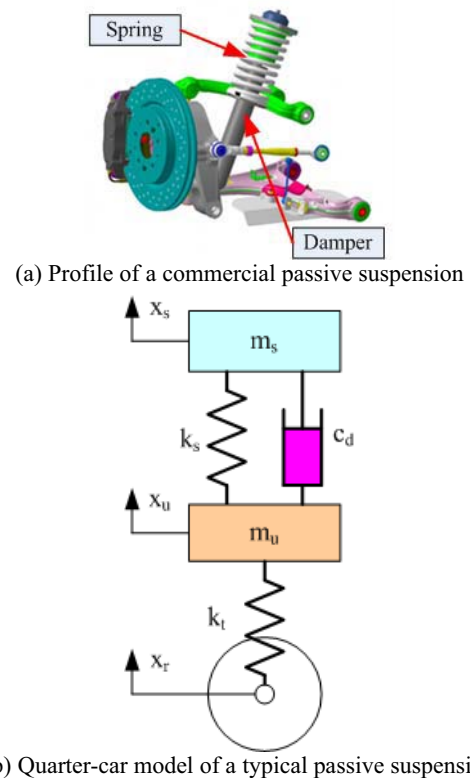

(b) Quarter-car model of a typical passive suspension  
Fig. 1: Illustration of a passive suspension

In Fig.1,  $m_s$  represents the sprung mass of the quarter-car,  $m_u$  represents the unsprung mass of the quarter-car,  $k_s$

This work is supported in part by the Innovation and Technology Fund of Hong Kong Innovation and Technology Support Programme and the Automotive Parts and Accessory Systems R&D Centre, Hong Kong (Project code: ITP/025/09AP).

represents the spring stiffness,  $c_d$  represents the damping coefficient,  $k_t$  represents the tire stiffness,  $x_b$  represents the vertical displacement of the sprung mass,  $x_u$  represents the vertical displacement of the unsprung mass, and  $x_r$  represents the vertical displacement of the road.

Good isolation requires low suspension frequencies (soft springs) and modest damping, whereas variations in the load whether generated by changes in the number of passengers and luggage, or through internal inputs generated during acceleration, braking and cornering, are reacted more effectively with stiff springs and relatively high damping rates. Firm tyre-to-road contact is also most effectively controlled with high damping rates [1]. For passive suspensions, clearly, a tradeoff is needed to resolve the conflict between ride comfort and good handling performance [3]. Passive suspension systems are popular in vehicles due to their simplicity, small volume, low cost and high reliability. However, passive suspensions can not give satisfactory results for suspension problems, because passive suspensions have constant elastic characteristics and damping characteristics, only respond to the external excitation passively, and do not allow any active control [6]. Consequently, the feasible improvements are in the field of shapes, valves and materials [4].

### 2. Semi-active Suspensions

A semi-active suspension is one without active force sources. Thus, the mechanical layout of a semi-active suspension is identical to a passive one. However, some control of damping coefficient is achieved by switching the characteristics of dampers. Consequently, this gives the possibility of the damper reaction forces. Usually, a semi-active suspension can be remotely electrically switched to either soften or stiffen the suspension. Its damping coefficient can be changed continuously or discontinuously. The switching strategy is to use stiff suspension at cornering, acceleration, and braking, to reduce the low frequency response to inertial forces associated with roll and pitch, and also to avoid exciting the body and wheel resonances. For large road wheel movements, moreover, it is often used to switch from the soft to hard settings to prevent crash-through of the suspension on irregular road surfaces. The soft setting is restored after a few seconds of fairly straight and constant speed driving. It can be seen that semi-active suspensions operate under closed-loop control. An example of a commercial electromagnetic semi-active suspension system is the magnetorheological damper installed in Audi car [1] [2] [7]. However, since it is a semi-active system, no active force can be applied and therefore, total roll and pitch elimination is impossible. The semi-active suspensions are applied commercially to the Audi's car as shown in Fig. 2a [8] and the quarter-car model of a typical semi-active suspension is depicted in Fig. 2b.

### 3. Active Suspensions

An active suspension is one including an actuator that can supply active force, which is regulated by a control algorithm using data from sensors attached to the vehicle. An active suspension is composed of an actuator and a mechanical spring, or an actuator, a mechanical spring and

a damper. It belongs to the high-bandwidth active suspension controlling both the sprung mass and the unsprung mass if the active actuator works mechanically in parallel with the spring. It is the low-bandwidth active suspension controlling the sprung mass if the active actuator works mechanically in series with the spring and the damper. In general, the frequency of the unsprung mass lies in the range of 10-15 Hz, and the frequency of the sprung mass lies in the range of 1-2 Hz. The cost of active suspensions depends on the required bandwidth. If the active suspension with the limited bandwidth is only required, the cost the actuator are reduced and hence the cost of the active suspension is reduced, too [1] [2] [9] [10]. Due to supplying active force control, active suspensions provide the possibility to fully accomplish the aims of automotive suspensions.

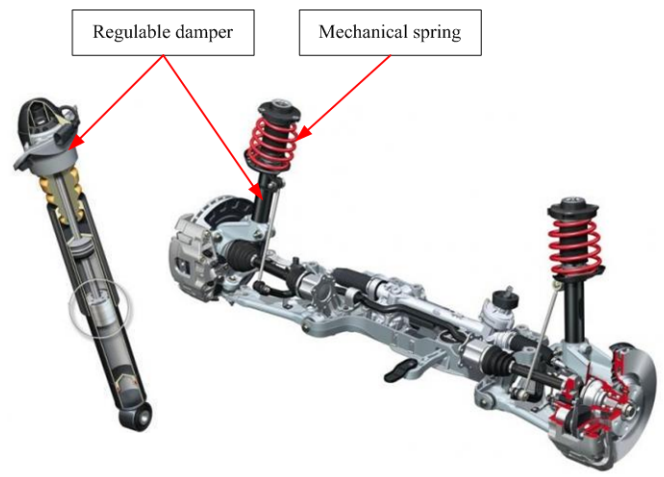

(a) Profile of the commercial semi-active suspensions

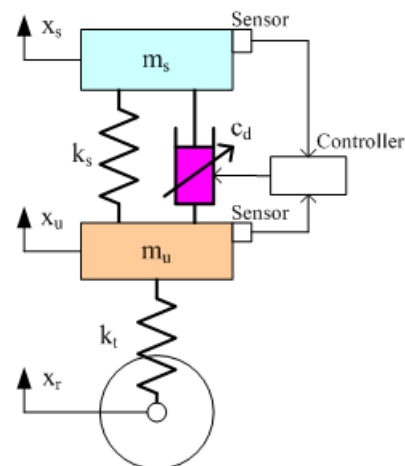

(b) Quarter-car model of a semi-active suspension

Fig. 2: Illustration of a typical semi-active suspension

The active suspension is named generally as the hydraulic or pneumatic one if the actuator is selected as the hydraulic or pneumatic actuator, and the active suspension is named generally as the electromagnetic one if the actuator is an electromagnetic actuator. Active suspensions commercially implemented in automobiles today are based on the hydraulic or pneumatic one [2] [11]. BMW developed an active roll control (BMW-ARC) system by placing a hydraulic rotary actuator in the center of the anti-roll bar at the rear of the vehicle, as shown in Fig. 3a [10] [12]. Three typical quarter-car models of active suspensions are illustrated in Fig. 3b-3d (the BMW 545

anti-roll system belongs to the low-bandwidth active suspension), where  $F_a$  represents the force produced by the actuator [1] [3] [9].

### III. HYDRAULIC OR PNEUMATIC ACTIVE SUSPENSIONS

A hydraulic or pneumatic active suspension consists of a hydraulic or pneumatic actuator, a damper, and a mechanical spring. In general, the hydraulic or pneumatic active suspensions are suitable for low-bandwidth applications. Hence, the typical quarter-car model of the hydraulic or pneumatic active suspensions has been illustrated in Fig. 3c.

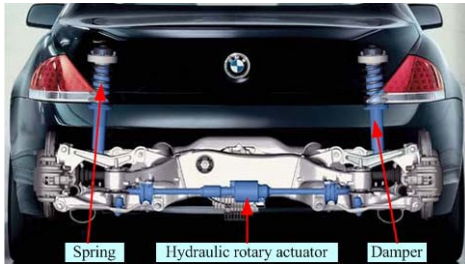

(a) Profile of the commercial low-bandwidth hydraulic active suspensions used in BMW 545

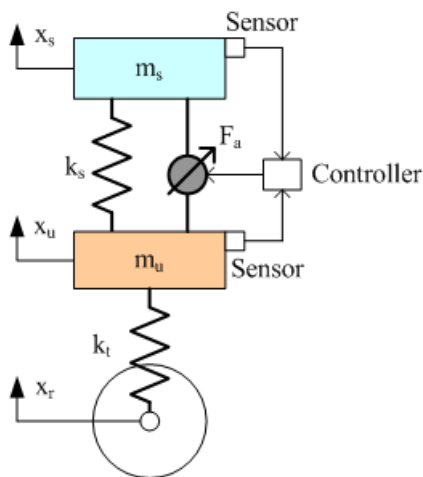

(b) Quarter-car model of a high-bandwidth active suspension

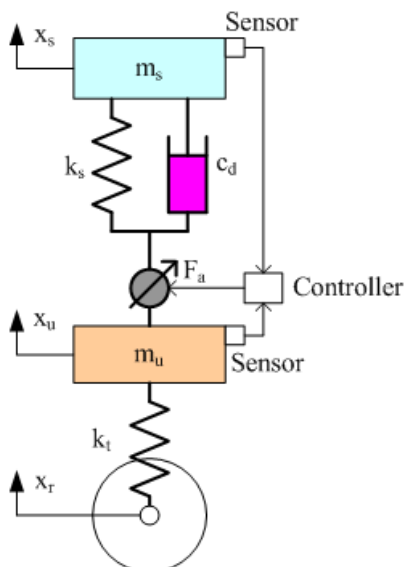

(c) Quarter-car model of a low-bandwidth active suspension

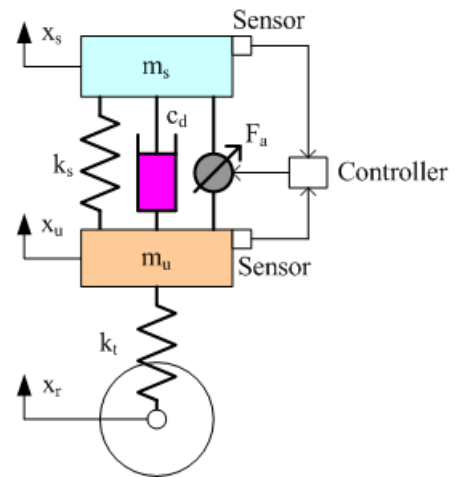

(d) Quarter-car model of a medium-bandwidth active suspension  
Fig. 3: Illustration of a hydraulic active suspension

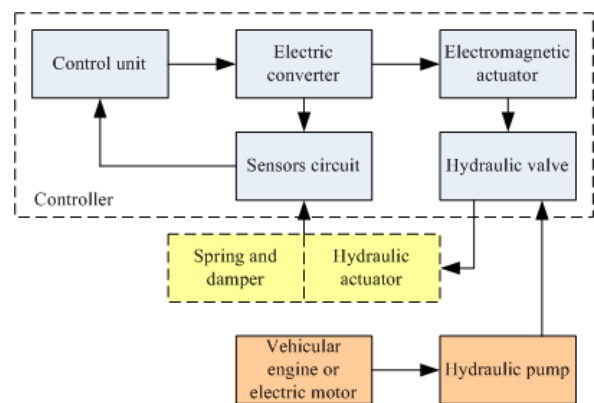

Fig. 4: Block diagram of control for hydraulic active suspension

In a hydraulic or pneumatic active suspension, the hydraulic or pneumatic cylinder works under motoring as a hydraulic or pneumatic actuator. It receives hydraulic or pneumatic energy from a pump driven by the vehicular engine or an electric motor. An electronic controller regulates the actuator force [4]. Fig. 4 shows the block diagram of the electronic controller of the hydraulic or pneumatic active suspension. The vehicle engine or the electric motor drives a hydraulic or pneumatic pump to supply the hydraulic or pneumatic energy to the hydraulic or pneumatic actuator involved in the hydraulic active suspension, which creates oscillation-damping forces between the vehicular sprung mass and the vehicular unsprung mass. The hydraulic or pneumatic valve is driven by the low-power electromagnetic actuator, which is controlled by the control unit with the electric converter, in order to regulate the force of the hydraulic or pneumatic actuator [9] [11].

Reference [9] presented an oleo-pneumatic actuator applied to a low-bandwidth active suspension and the structure of the oleo-pneumatic actuator and the control system are also described. A commercial low-bandwidth hydraulic active suspension (active roll control system) was illustrated in [10]. In [11], the control schematic and the quarter-car model of the hydraulic active suspension were illustrated. The optimization of both the elastic constant of the spring and the characteristic coefficient of the damper in the hydraulic active suspension was investigated in order to minimize the power required for

the operation of the active suspension in [13]. In [14], an adaptive observer was developed for observer-based parameter identification in the hydraulic active suspension system. A previously developed nonlinear sliding control law was applied to the hydraulic active suspension system in [15]. Reference [16] described the active stabilizer bar system developed by BMW, which belongs to hydraulic active suspension. The system consists of a hydraulic pump with oil reservoir, lateral acceleration sensor, electronic control unit, hydraulic valve block, and two active stabilizer bars with rotating hydraulic actuators. Its functions are (a) significantly to reduce roll angle during cornering; (b) dynamically to adjust the self-steering characteristics as a function of vehicle speed and driving conditions, resulting in improved handling, agility, and steering precision; and (c) to eliminate a negative side effect of passive stabilizer bars. Reference [17] presented the modeling and force tracking control of a non-linear hydraulic actuator applied in a quarter-car hydraulic active suspension system.

All active suspensions implemented in automobiles today are based on hydraulic or pneumatic operation. Except the BMW-ARC system shown in Fig. 3a, another commercial example is given by the active body control (ABC) system of Mercedes-Benz. This system includes the steel springs hydraulic strut, high-pressure accumulator, hydraulic pump, dampers, sensors, and electronic control unit. With the ABC, the suspension struts are positioned between the wheels and the vehicle body. The hydraulic system is controlled by an electronic unit that analyses numerous sensor signals emitted while the vehicle is moving. The ABC system controls oil flow into the spring struts at each wheel independently. The movement of the hydraulic actuators compensates the unevenness of road and hence the movement of the body is largely reduced. Furthermore, the ABC system slowly lowers the vehicle at higher speeds. Fig. 5 illustrates the ABC system [18] [19].

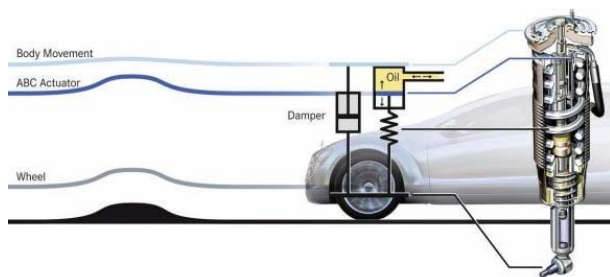

(a) Hydraulic active suspension for the ABC system



(b) ABC system equipped on a car

Fig. 5: Profiles of the active body control system developed by Mercedes-Benz

However, it is found that these solutions do not satisfactorily solve the vehicle oscillation problem, or they are very expensive and complicated, and increase the vehicle's energy consumption [11]. This expensive and complicated system is used only in luxury automobiles [4] [20].

#### IV. ELECTROMAGNETIC ACTIVE SUSPENSIONS

In general, an electromagnetic active suspension is composed of an electromagnetic actuator and a mechanical spring. Both components work mechanically in parallel. The natural control flexibility of the electromagnetic actuator results in the important improvement in the suspension behavior, because the active suspension can produce the active control force to absorb road shocks rapidly, suppress the roll and pitch motions, and ameliorate both safety and comfort. Furthermore, the other potential merit of the electromagnetic active suspensions is that the electromagnetic actuator can work under generating. This characteristic allows energy recovery from the suspension, when the actuator produces the damping force. Thus, the vehicular energy consumption decreases [4].

Linear motion can be achieved by an electromagnetic rotary motor with a ball-screw or other transducer to transform the rotary motion to linear translation. Such a suspension including the electromagnetic rotary motor belongs to the electromagnetic indirect-drive active suspension. The mechanism required to make this conversion results in considerable complications, which include backlash and increased mass of the moving part due to connecting transducers or gears that convert rotary motion to linear motion. It should be noted that these complications introduce an infinite inertia and therefore, a series suspension is preferable as shown in Fig. 3c, where the actuator is regarded as a rotary motor connected to a ball-screw bearing. The electromagnetic active suspension including the electromagnetic linear actuator is direct-drive. It is more suited to a parallel suspension as shown in Fig. 3b, where the inertia of the electromagnetic linear actuator is minimized [21] [22].

The block diagram of the electronic controller of the electromagnetic active suspensions is depicted in Fig. 6. The electromagnetic actuator is driven by the electric converter and controlled by the control unit based on the acquired signals and the control algorithms. The actuator power is supplied by the battery, which can be fed by the electric generator driven by the vehicular engine. Thus, the battery now replaces the complex and expensive hydraulic components. At the same time, the energy stored in the electromagnetic active suspension can be fed back to the battery via the electric converter if the electromagnetic actuator works under generating.

A number of publications reported studies and investigations of electromagnetic active suspensions. The electromagnetic active suspension presented in [4] includes a permanent-magnet linear actuator, a damper and a mechanical spring, which work mechanically in parallel. Furthermore, the performances of the electromagnetic active suspension was computed and

analyzed. In [7], the electromagnetic active suspension, which consists of a slotless brushless tubular permanent-magnet actuator and a spring as shown in Fig. 3b, was presented. Based upon measurements, static and dynamic specifications of the actuator are discussed. Furthermore, the optimization design of the actuator was proposed. In [10], the force and power requirement of the electromagnetic active suspension, where the permanent-magnet linear actuator works mechanically in parallel with the spring, was discussed. In addition, the optimized design is investigated by using the developed algorithm. The analysis and the experimental results presented in [11] show that the electromagnetic linear actuator is suitable for application in the electromagnetic active suspension, which is composed of the permanent-magnet linear actuator and the spring, as shown in Fig. 3b. On a quarter-car setup, the dynamic capabilities of an electromagnetic suspension combining a tubular permanent-magnet actuator and a spring as shown in Fig. 3b were examined in [22]. In [23], the feature of power recovery of the electromagnetic active suspension was studied based on the power spectral density analysis and computer simulations. Reference [24] reported that the Bose active suspension system was developed and equipped in a car prototype. Some tests on the car prototype with the Bose active suspension system have been done successfully, such as cornering, slalom, and bump double-lane change [25]. The energy recuperation and management in electromagnetic active suspension systems were studied in [26], based on the model shown in Fig. 3d. An indirect-drive electromagnetic active suspension including an electromagnetic rotary actuator and reduction gear was proposed in [27], to control roll, pitch, and bounce. Its quarter-car model is similar to Fig. 3d and the difference is that the actuator in series with a torsion spring replaces the actuator in Fig. 3d. Furthermore, the effect on the drivers' motion was investigated when the roll control was on and off by means of the developed roll oscillation simulator. Based on on-road measurements and results from the literature, at the same time, several specifications for the design of an electromagnetic suspension system are derived. In [28], a model-based design of the controller for an electromagnetic active suspension as shown in Fig. 3b was described. Moreover, the achieved reduction of vibrations is proofed by the measurements obtained by road tests. The modified lead-lag control, linear-quadratic servo control with a Kalman filter, and fuzzy control methodologies were implemented for electromagnetic active suspension controls in [29]. In [30], the energy regeneration of the electromagnetic active suspension system was investigated in hybrid electric vehicles based on the developed simulation algorithms.

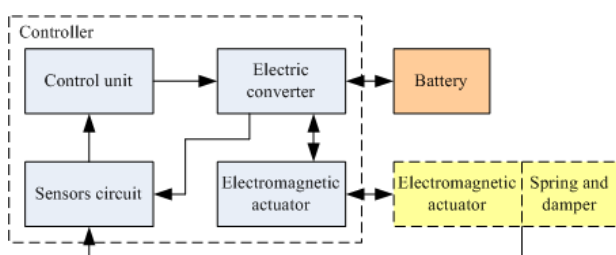
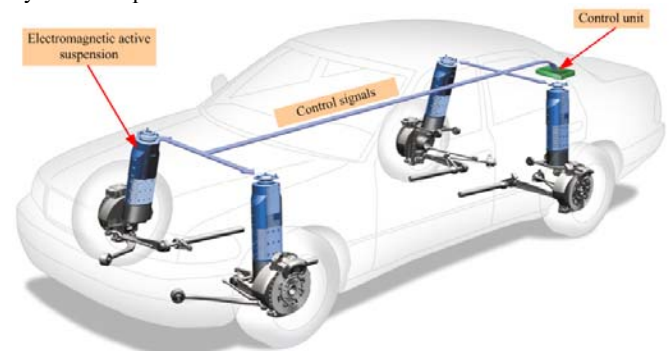

Fig. 6: Block diagram of control for an electromagnetic active suspension

Up to now, it is most closed to the commercial products that the prototypes of electromagnetic active suspensions were developed by Bose Corporation. Fig. 7 shows the profiles of the Bose electromagnetic active suspension system, which includes linear electromagnetic motors, power amplifiers, torsion spring, and a set of control algorithms. The high bandwidth linear electromagnetic motor is installed at each wheel. This linear electromagnetic motor responds quickly enough to counter the effects of bumps and potholes, while maintaining a comfortable ride. Electrical power is delivered to the motor by a power amplifier in response to signals from the control algorithms. The bi-directional power amplifier allows power to flow into the linear electromagnetic motor and also allows power to be returned from the motor [25].



(a) Prototype of the electromagnetic active suspension developed by Bose Corporation



(b) Schematic diagram of the Bose active suspension system  
Fig. 7: Profiles of the electromagnetic active suspension system developed by Bose Corporation

## V. COMPARISONS

From the aforesaid description and discussion, the disadvantages and advantages of various automotive suspensions can be summarized as follows.

### 1. Passive Suspensions

Because a passive suspension consists of a damper and a spring, the passive suspension has the following advantages: (a) simple and firm structure, (b) small volume, (c) low weight, (d) low cost, and (e) high reliability. The disadvantages of passive suspensions are as follows: (a) the damping characteristics affects both ride comfort and handling performance, and hence passive suspensions are difficult to accomplish ride comfort and good handling performance simultaneously; and (b) when

the vibration frequency of the suspension is below 0.7Hz, passengers are easily carsick, and it probably leads to mechanical resonance in the vehicle body [6].

## 2. Semi-active Suspensions

In comparison with passive suspensions, semi-active suspensions improve damping characteristics under closed-loop control. Hence, roll and pitch motions of the car body are suppressed considerably. In addition, semi-active suspensions have the advantages of easy control, small volume, low weight, and adequate cost. The disadvantages are that roll and pitch motions can not be eliminated fully.

## 3. Hydraulic or Pneumatic Active Suspensions

The advantages of hydraulic or pneumatic active suspensions can be summarized as: (a) high force density, (b) active force control, (c) effective elimination of roll motions, (d) commercial availability of the various parts, and (f) commercial maturity [21] [22]. The disadvantages can be described as: (a) low-bandwidth due to high system time constant, (b) environmental pollution due to hose leaks and ruptures, where hydraulic fluids are toxic, (c) no energy regeneration due to irreversible actuator, (d) complex structure, and (e) high cost [21] [22].

## 4. Electromagnetic Active Suspensions

Because electromagnetic active suspensions can produce the active forces under various situations of load, velocity, drive and road, an active suspension system keeps good ride quality and handling performance in all working conditions. In comparison with hydraulic active suspensions, in addition, electromagnetic active suspensions have the following advantages: (a) improved dynamic behavior; (b) improved stability; (c) accurate force control; (d) energy regeneration due to reversible operation of the electromagnetic actuator; (e) high-bandwidth operation; (f) oil-free system; (g) flexible control; and (h) simple structure. The disadvantages include increased volume and weight in comparison with hydraulic active suspensions [21] [22].

## 5. Comparisons

Based on the aforesaid description and discussion, the classification of automotive suspensions and comparisons between various vehicular suspensions can be deduced. Fig. 8 illustrates the classification of automotive suspensions and the comprehensive comparisons between various automotive suspensions are described in Table I.

## VI. CONCLUSION

Based on numerous publications on automotive suspensions, investigations, studies and developments of automotive suspensions have been reviewed in this paper. Furthermore, structures, models, and features of various automotive suspensions have been described. As for the aspects of structure, weight, cost, ride comfort, handling performance, reliability, dynamic performance, energy regeneration, and commercial maturity, the comparisons between various automotive suspensions have been given in this paper.

Electromagnetic active suspensions will be the future trend of automotive suspensions due to simple structure, high-bandwidth operation, accurate and flexible force control, high ride quality, good handling performance, and energy regeneration. The future research and development of electromagnetic active suspensions should focus on two aspects. One of which is to research and develop electromagnetic linear actuators and the other is to research and develop control for the electromagnetic active suspensions and systems. The former includes configuration design, electromagnetic design, and design optimization for high force density. The latter contains development of control methods, design of control systems, and implementation of control algorithms.

The present studies of electromagnetic active suspensions handle with permanent-magnet linear actuators, in which rare-earth materials are used in order to enhance force density. The linear switched reluctance actuator should be the feasible alternative, due to its simple and firm configuration, low cost, and sustainable development without any rare-earth materials.

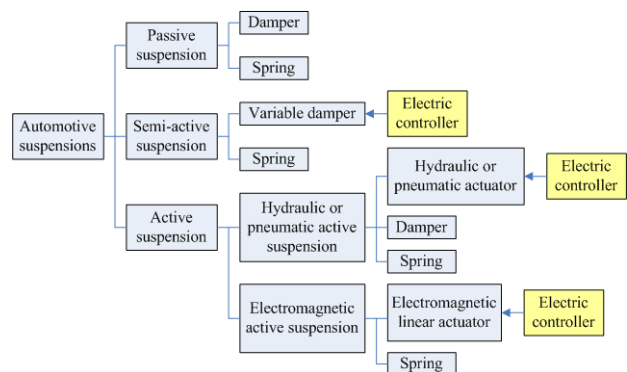

Fig. 8: Classification of automotive suspensions

Table I Comparisons between various automotive suspensions

Parameters	Passive suspensions	Semi-active suspensions	Hydraulic or pneumatic active suspensions	Electromagnetic active suspensions
Structure	Simplest	Complex	Most complex	Simple
Weight or volume	Lowest	Low	High	Highest
Cost	Lowest	Low	Highest	High
Ride comfort	Bad	Medium	Good	Best
Handling performance	Bad	Medium	Good	Best
Reliability	Highest	High	Medium	High
Dynamic performance	Passive	Passive	Medium	Good
Energy regeneration	No	No	No	Yes
Commercial maturity	Yes	Yes	Yes	No

## REFERENCES

- [1] R. A. Williams, "Electronically controlled automotive suspensions", *Computing & Control Engineering Journal*, Volume: 5, Issue: 3, 1994, pp. 143-148
- [2] M. Appleyard and P.E. Wellstead, "Active suspensions: some background", *IEE Proc.-Control Theory Appl.*, Vol. 142, No. 2, March 1995, pp. 123-128
- [3] J. Cao, H. Liu, P. Li, and D. J. Brown, "State of the Art in Vehicle Active Suspension Adaptive Control Systems Based on Intelligent Methodologies", *IEEE TRANSACTIONS ON INTELLIGENT TRANSPORTATION SYSTEMS*, VOL. 9, NO. 3, SEPTEMBER 2008, pp. 392-405.
- [4] I. Martins, M. Esteves, F. Pina da Silva, and P. Verdelho, "ELECTROMAGNETIC HYBRID ACTIVE-PASSIVE VEHICLE SUSPENSION SYSTEM", *1999 IEEE 49th Vehicular Technology Conference*, Vol. 3, 1999, pp. 2273-2277.
- [5] Website: <http://www.automobilesreview.com/auto-news/maserati-quattroporte-sport-gt-s-2/13824/>.
- [6] X. Li; K. Tian; H. Li; D. Chen; L. Li; T. Meng; and C. Zhang; "Active Suspensions Based on the Principles of Giant Magnetostriction", *2008 IEEE Vehicle Power and Propulsion Conference*, 2008, pp. 1-4.
- [7] Bart L. J. Gysen, Jeroen L. G. Janssen, Johannes J. H. Paulides, and Elena A. Lomonova, "Design Aspects of an Active Electromagnetic Suspension System for Automotive Applications", *IEEE TRANSACTIONS ON INDUSTRY APPLICATIONS*, vol. 45, no. 5, SEPTEMBER/OCTOBER 2009, pp. 1589-1597.
- [8] Website: <http://www.gizmag.com/go/5752/>.
- [9] R. A. Williams, and A. Best, "Control of a low frequency active suspension", *International Conference on Control*, Vol. 1, 1994, pp. 338-343.
- [10] J. J. H. Paulides, L. Encica, E.A. Lomonova, and A.J.A. Vandenput, "Active roll compensation for automotive applications using a brushless direct-drive linear permanent magnet actuator", *37th IEEE Power Electronics Specialists Conference*, 2006, pp. 1-6
- [11] I. Martins, J. Esteves, G. D. Marques, and F. P. da Silva, "Permanent-Magnets Linear Actuators Applicability in Automobile Active Suspensions", *IEEE TRANSACTIONS ON VEHICULAR TECHNOLOGY*, VOL. 55, NO. 1, JANUARY 2006, pp. 86-94.
- [12] Website: [http://www.bmw.com/com/en/newvehicles/6series/coupe/2007/allfacts/engine\\_dynamicdrive.html](http://www.bmw.com/com/en/newvehicles/6series/coupe/2007/allfacts/engine_dynamicdrive.html)
- [13] G. Corriga, S. Sanna, and G. Usai, "An Optimal Tandem Active-Passive Suspension System for Road Vehicles with Minimum Power Consumption", *IEEE TRANSACTIONS ON INDUSTRIAL ELECTRONICS*, VOL. 38, NO. 3, JUNE 1991, pp. 210-216
- [14] R. Rajamani and J. K. Hedrick, "Adaptive observers for active automotive suspensions: Theory and experiment," *IEEE Trans. Contr. Syst. Technol.*, vol. 3, Mar 1995, pp. 86-93.
- [15] A. Alleyne and J. Hedrick, "Nonlinear adaptive control of active suspension," *IEEE Trans. Contr. Syst. Technol.*, vol. 3, Mar 1995 pp. 91-101.
- [16] M. Strassberger and J. Guldner, "BMW's dynamic drive: An active stabilizer bar system," *IEEE Control Syst. Mag.*, vol. 24, no. 4, Aug 2004, pp. 28-29.
- [17] Y. M. Sam and K. Hudha, "Modelling and force tracking control of hydraulic actuator for an active suspension," in *Proc. 1st IEEE Conf. Ind. Electron. Appl.*, May 24-26, 2006, pp. 1-6.
- [18] Website: <http://www.mercedes-benz.com.cn/.../comfort.0002.html>
- [19] Website: <http://www.caradvice.com.au/.../>
- [20] J. G. Kassakian, H.-C. Wolf, J. M. Miller, and C. J. Hurton, "THE FUTURE OF AUTOMOTIVE ELECTRICAL SYSTEMS", *Power Electronics in Transportation*, 1996, pp. 3-12.
- [21] Bart L.J. Gysen, Johannes J.H. Paulides, Jeroen L.G. Janssen, and Elena A. Lomonova, "Active Electromagnetic Suspension System for Improved Vehicle Dynamics", *2008 IEEE Vehicle Power and Propulsion Conference*, 2008, pp. 1-6.
- [22] Bart L. J. Gysen, Johannes J. H. Paulides, Jeroen L. G. Janssen, and Elena A. Lomonova, "Active Electromagnetic Suspension System for Improved Vehicle Dynamics", *IEEE TRANSACTIONS ON VEHICULAR TECHNOLOGY*, VOL. 59, NO. 3, MARCH 2010, pp. 1156-1163.
- [23] Hsu, P.; "POWER RECOVERY PROPERTY OF ELECTRICAL ACTIVE SUSPENSION SYSTEMS", *Energy Conversion Engineering Conference*, vol. 3, 1996, pp. 1899-1904
- [24] W. D. Jones, "Easy Ride", *IEEE Spectrum*, Vol. 42, Issue 5, 2005, pp. 12-14
- [25] Website: <http://www.bose.com/controller?url=/automotive/index.jsp>
- [26] A. Stribrsky, K. Hyniova, J. Honcu, A. Kruczek, "Energy Recuperation in Automotive Active Suspension Systems with Linear Electric Motor", *Mediterranean Conference on Control & Automation (MED '07)*, 2007, pp. 1-5
- [27] S. Buma, H. Kajino, T. Takahashi, and S. Doi, "Consideration of a Human Dynamic Characteristic and Performance Evaluation of an Electric Active Suspension", *IEEE/ASME International Conference on Advanced Intelligent Mechatronics*, 2008, pp. 1030-1036.
- [28] C. Graf, J. Maas, and H.-C. Pflug, "Concept for an Active Cabin Suspension", *2009 IEEE International Conference on Mechatronics*, 2009, pp. 1-6
- [29] Seungho Lee and Won-jong Kim, "Active Suspension Control With Direct-Drive Tubular Linear Brushless Permanent-Magnet Motor", *IEEE TRANSACTIONS ON CONTROL SYSTEMS TECHNOLOGY*, vol. 18, no. 4, JULY 2010, pp. 859-870.
- [30] Morteza Montazeri-Gh and Mehdi Soleymani, "Investigation of the Energy Regeneration of Active Suspension System in Hybrid Electric Vehicles", *IEEE TRANSACTIONS ON INDUSTRIAL ELECTRONICS*, VOL. 57, NO. 3, MARCH 2010, pp. 918-925.